

VISY-X

VISY-RF III wireless system



Version: 3
Edition: 2019-04
Art. No.: 350272

Contents

1	Introduction.....	1
1.1	In this manual	1
1.2	Requirements of service engineers.....	1
1.3	Safety precautions.....	2
1.4	Recommended tools.....	2
2	Components.....	4
3	Intended use	4
4	System installation.....	4
4.1	General installation diagram	4
4.2	Transmitter installation.....	5
4.2.1	VISY-Stick pipe installation (riser).....	6
4.2.2	VISY-Stick with screw-in unit.....	7
4.2.3	Commissioning the VISY-RFT-L transmitter module.....	7
4.3	VISY-Command RF installation.....	10
4.3.1	Antenna for the receiver	10
5	Commissioning.....	12
5.1	VISY-RFT-L transmitter module.....	12
5.1.1	Jumper setting	13
5.1.2	Service mode.....	14
5.1.3	Normal operation	14
5.1.4	Status code.....	14
5.2	Procedure for checking the radio signal quality.....	15
6	General notes and troubleshooting.....	18
6.1	Radio signal losses	18
6.2	Radio line of sight.....	18
6.3	Interference radiation.....	18
6.4	Equipment location.....	18
6.5	Error codes and troubleshooting tips.....	19
6.6	Battery.....	19
7	Technical Data	20
7.1	General data	20
7.2	VISY-RFT-L transmitter.....	20
7.3	VISY-RFR receiver (in VISY-Command RF)	20
8	Annex.....	21
8.1	EC Declaration of Conformity VISY-RFT-L.....	21
8.2	EC Declaration of Conformity VISY-RFR-D.....	22

8.3	EC type-examination certificate ATEX 554018 X.....	23
8.4	Operating Instructions VISY-RFT-L.....	26
8.5	List of figures.....	29
8.6	Tables.....	29

© Copyright:

Reproduction and translation are permitted only with the written consent of the FAFNIR GmbH. FAFNIR GmbH reserves the right to carry out product alterations without prior notice.

1 Introduction

The VISY-X system is a data collection system for fuel tanks and environmental sensors at petrol stations. It consists of VISY sensors, which are connected to the VISY-Command central unit installed in the petrol station building. The VISY-Command collects the data from the sensors and transmits them on request to a higher-level system (e.g. POS).

In most cases, the VISY-Stick sensors are electrically connected to the VISY-Command central unit by a cable. The sensors are powered by a cable, which ensures a high level of data safety.

Sometimes, there might be no free cable ducts between the manhole and VISY-Command. Then the radio system with the VISY-Command RF central unit can be an attractive alternative because no excavation work is required. In the wireless system, the VISY sensors (VISY-Stick, VISY-Stick Sump, ...) and the VISY-RFT-L transmitters are powered by a battery. The installation procedure for the VISY-RF wireless system is described on the pages that follow.

1.1 In this manual ...

... you are guided through the installation and set-up of the VISY-RF wireless system.

These instructions contain a description of all the steps needed to perform the installation and commissioning of the wireless system.

During installation of the VISY-RF wireless system, it is necessary to configure the VISY-Command RF using the VISY-Setup configuration software. Please follow the appropriate instructions mentioned in the VISY-Setup manual.



Useful tips and information in this manual, you should observe, appear in italics and are identified by this symbol.



If these safety instructions are not observed, it may result in the risk of accident or damage to the VISY-X system.

1.2 Requirements of service engineers

All parts of the VISY-RF wireless system should be installed only by trained service engineers.

1.3 Safety precautions

Observe and follow all product safety notes and operating instructions. The following safety precautions must be observed in order to reduce the risk of injury, electric shocks, fire or damage to the equipment:

- This product should only be used in conjunction with FAFNIR components.
- After opening the case cover of the VISY-Command RF there is a risk of electric shock when touching live parts.
- In the interests of explosion safety, only the use of original FAFNIR batteries is permitted.
- The VISY-RFT-L transmitter module must never be operated without the transmitter antenna connected.
- Where external antennas are installed, all applicable rules and regulations governing lightning and surge voltage protection must be observed.
- Make sure that the VISY-RFT-L transmitter in the manhole is never submerged in water.

1.4 Recommended tools

- Laptop, RS 232 communication cable, VISY-Setup
- VISY-RF Meter, portable field-strength meter portable, 433.92 MHz, Art. No. 900090

The VISY-RF Meter enables you to check for the presence and strength of a 433 MHz radio signal. During installation of the VISY-RF wireless system, this instrument is a useful means of determining the optimum position for the receiver antenna, of evaluating the signal strength of the VISY-RFT-L transmitter to be installed, and of identifying whether other radio signals may be present (interference radiation).



Use of the VISY-RF Meter in potentially explosive atmospheres is strictly prohibited.

To switch on the meter, press the button briefly. The instrument switches off automatically after two minutes. The series of LEDs indicate radio activity in the local area. The measured maximum field strength value is displayed for 1 second. The green area of the LED display indicates the presence of a strong radio signal, the red area of a weak radio signal.

The VISY-RF Meter is powered by a 9 V square battery (6LR61).



Figure 1: VISY-RF Meter

2 Components

The following components are required for the VISY-RF wireless system:

- VISY Sensors (VISY-Stick, VISY-Stick Sump, ...)
- VISY-RFT-L transmitter module
- VISY-Antenna
- VISY-Command RF with Interface VI-... and VISY-RFR receiver module

The **VISY-RFT-L transmitter module** is powered by an intrinsically safe battery pack.

The data from the VISY sensors is sent by the VISY-RFT-L transmitter module to the **VISY-RFR receiver module** and is forwarded to the Interface VI-... . The VISY-RFR receiver module has a built-in 230 VAC power supply.

For installation of the **VISY-Stick** and the **VISY-Command RF**, please refer to the most current edition of the following Technical Documentation:

- VISY-Stick VISY-Reed, art. no. 207194
- VISY-Command, art. no. 207184

3 Intended use

The VISY-RFT-L transmitter module is approved for use in potentially explosive atmospheres.

VISY-Command RF must be installed outside the explosion hazard zone.

4 System installation

4.1 General installation diagram

Below the Figure 2 shows a typical petrol station layout. The VISY-Stick sensor (1) is fitted inside the tank. The sensor connected to the VISY-RFT-L transmitter module (2) and is powered by an intrinsically safe battery inside the VISY-RFT-L transmitter module. The transmitter module generates radio signals, represented in the figure by semicircles. These radio signals are received by an antenna (3) and are forwarded to VISY-Command RF (4) along a 50-ohm coaxial cable. For viewing, the evaluated data can be forwarded to other peripheral equipment (VISY-View Touch, POS, BOS, etc.).

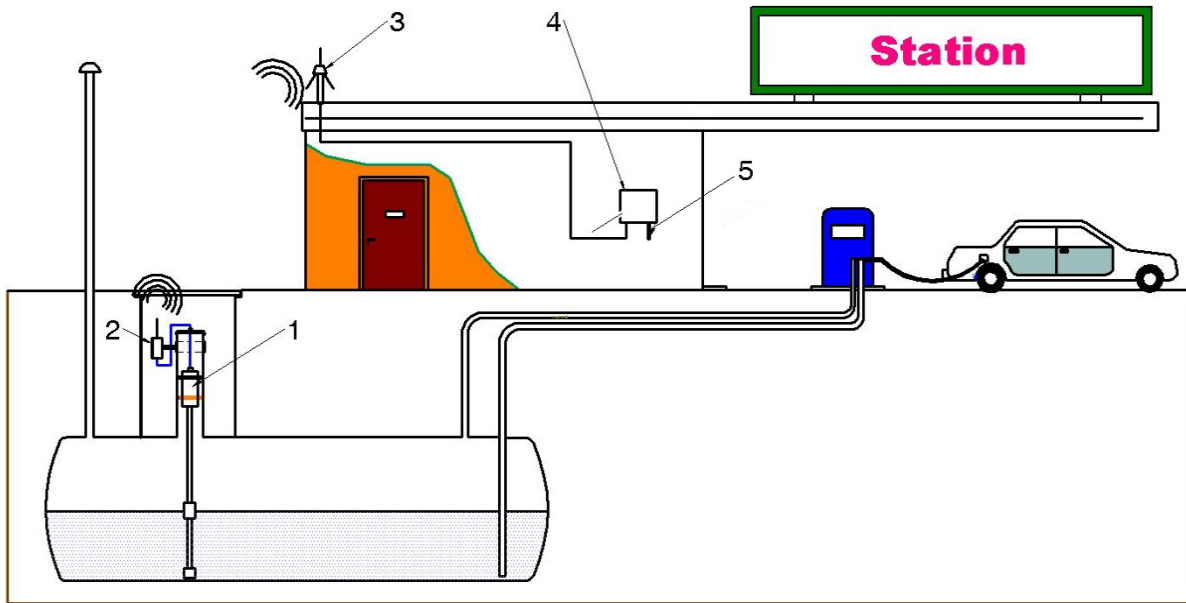

Figure 2 Typical layout of a petrol station

- 1 – VISY-Stick
- 2 – VISY-RFT-L transmitter module
- 3 – External VISY antenna (accessory)
- 4 – VISY-Command RF
- 5 – Connector for second antenna



In any installation, you should determine the optimum position for the transmitter and receiver antennas so that the maximum possible field strength is achieved.

4.2 Transmitter installation

The VISY-RFT-L transmitter module should be shielded as little as possible and mounted at the highest point possible inside the manhole to remain functional even when there is water in the manhole. The Figure 3 to 6 show the propagation patterns of radio waves under typical conditions.



The VISY-RFT-L transmitter module may only be operated with the connected transmitter antenna.

4.2.1 VISY-Stick pipe installation (riser)

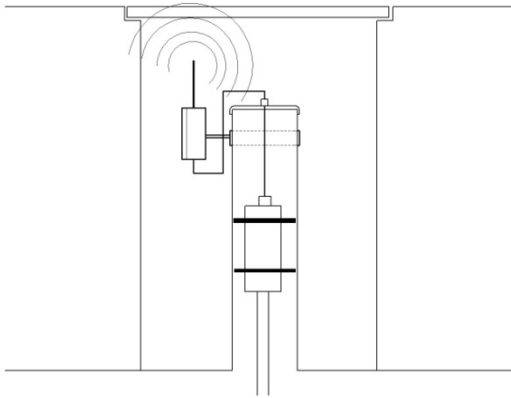

Figure 3: manhole with plastic cover
Radio transmission with minimal attenuation

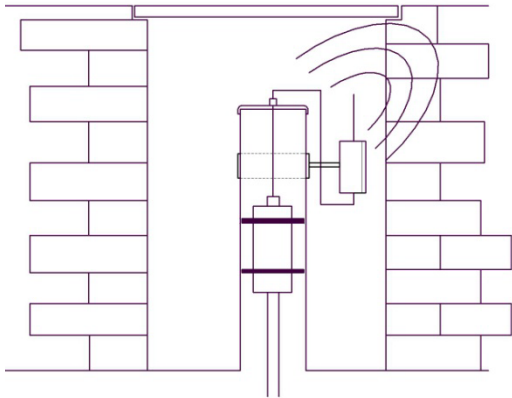

Figure 4: walled manhole with metal cover
Radio transmission with significant attenuation

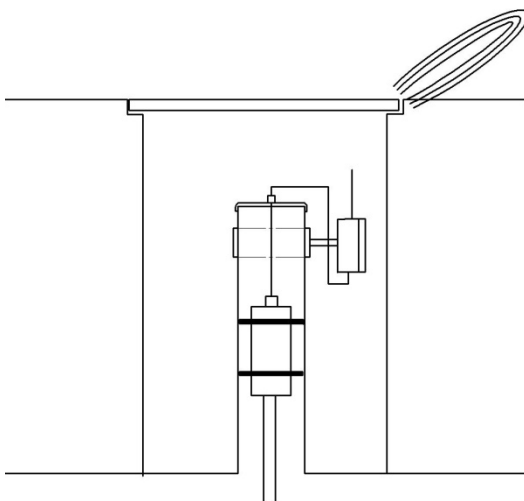

Figure 5: welded (metal) manhole with metal cover
Strong shielding (Faraday cage); only a small part of the radio signal finds passage if a slot is present

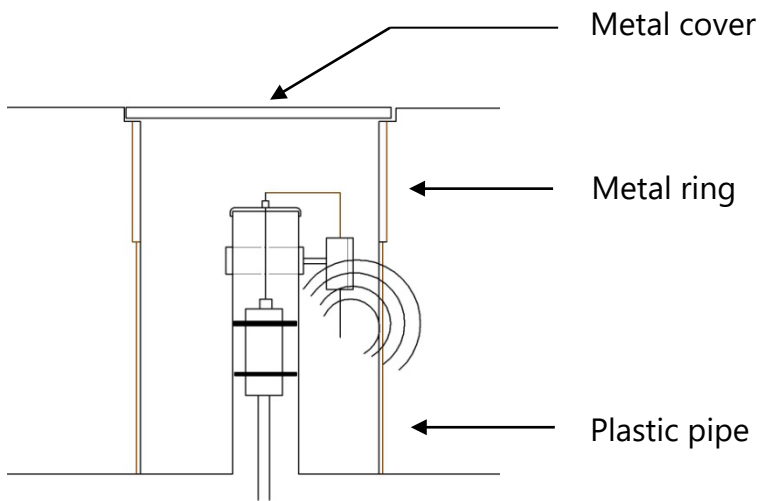

Figure 6: manhole with metal ring and metal cover
Radio signal passes through the plastic pipe underneath the metal ring, moderate attenuation

4.2.2 VISY-Stick with screw-in unit

Figure 3 to Figure 6 similarly apply to installation of the VISY-RFT-L transmitter module in conjunction with the VISY-Stick with screw-in unit.

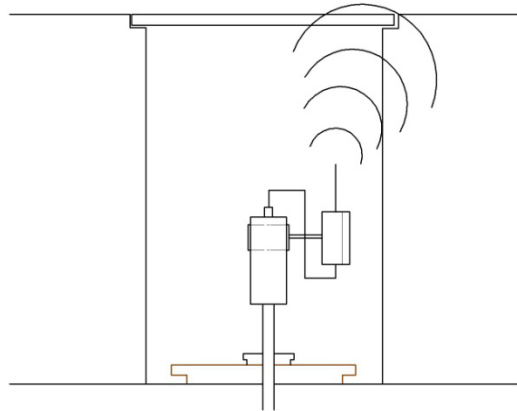

Figure 7: manhole with plastic cover
Radio transmission with minimal attenuation

To install the VISY-Stick and the VISY-RFT-L, proceed as follows:

- Fit the VISY-Stick inside the pipe (riser) in the tank or using the screw-in unit (R 1½).

4.2.3 Commissioning the VISY-RFT-L transmitter module

- The VISY-RFT-L transmitter module is equipped with a 4-core cable and M12 coupler.

- For installations with screw-in unit, the M12 coupler can be connected directly to the VISY-Stick. First tighten the union nut of the M12 coupler by hand and then tighten it further through 180° using a spanner.
- For installations with pipe installation (riser), there must be a cable gland present in the seal cap of the pipe cover. The connection cable can be disconnected from the transmitter module and fed through the cable gland of the pipe cover.
- Screw the transmitter antenna into the relevant thread on the transmitter module.
- Open the cover of the VISY-RFT-L transmitter module and use the jumper to select the required settings (see chapter 5.1.1). Connect the battery plug to the corresponding contacts (see Figure 9). Check that the LED lights up for three seconds as soon as the connector is connected. Place the silica gel back inside the housing and close the cover.
- It is possible to attach the VISY-RFT-L radio transmitter to a pipe using the VISY-RFT installation kit (Art. No. 910040). At first, the antenna should be aligned vertically. Final antenna alignment and orientation of the housing will be determined by the quality of radio transmission (see following section).

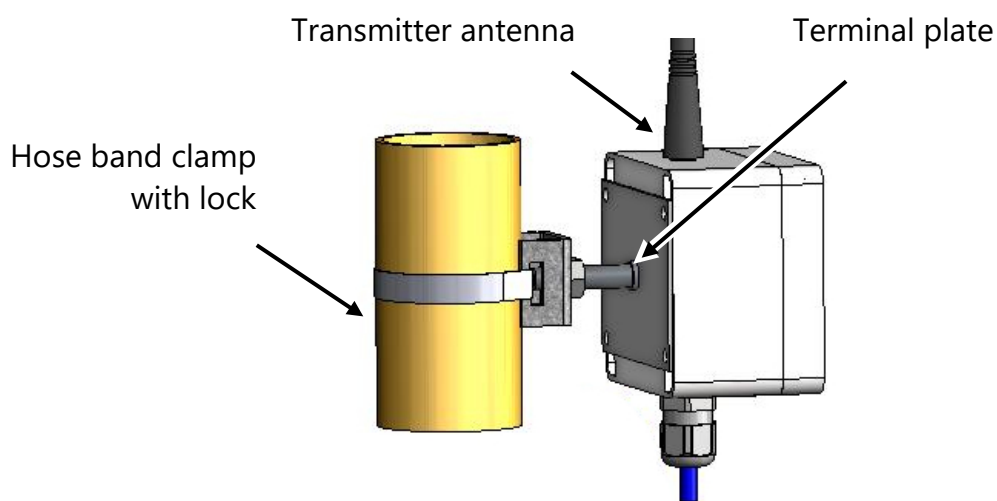



Figure 8 Installation Kit VISY-RFT

-  *Make sure that the dessicant (silica gel) has been placed inside the VISY-RFT-L transmitter module to prevent corrosion of the printed circuit boards.*
-  *The radio path between transmitter module and receiver antenna should not be interrupted by objects, so that the transmission of data is not disturbed.*

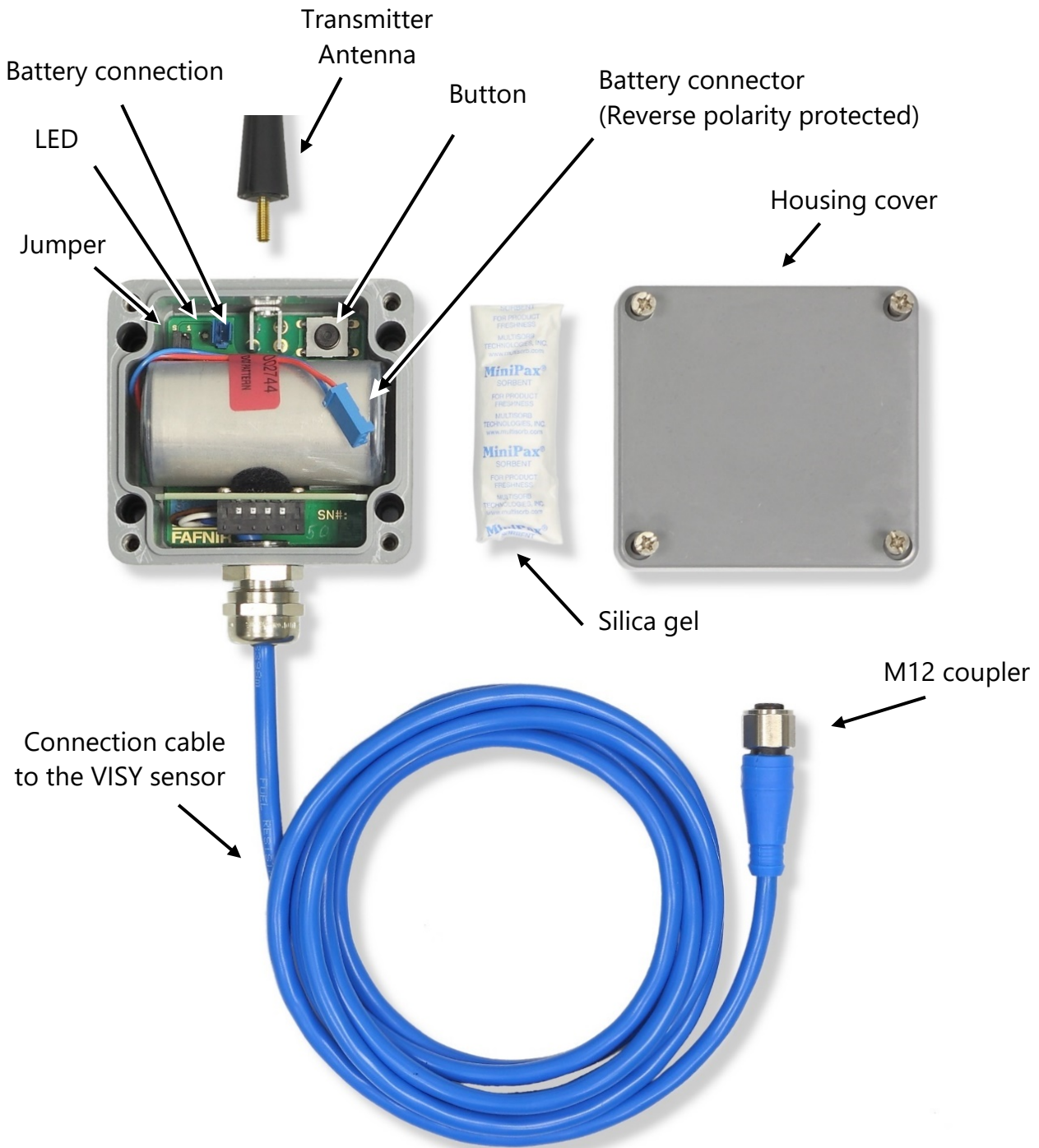



Figure 9: VISY-RFT-L transmitter module with cover removed

4.3 VISY-Command RF installation

The VISY-RFR receiver module is built into VISY-Command RF (4). An antenna (3) can be directly plugged into the BNC connector. To improve the reliability of transfer and on large installations, it is advisable to install a second antenna to the antenna connector (5).

 *Observe local building regulations concerning external antennas.*

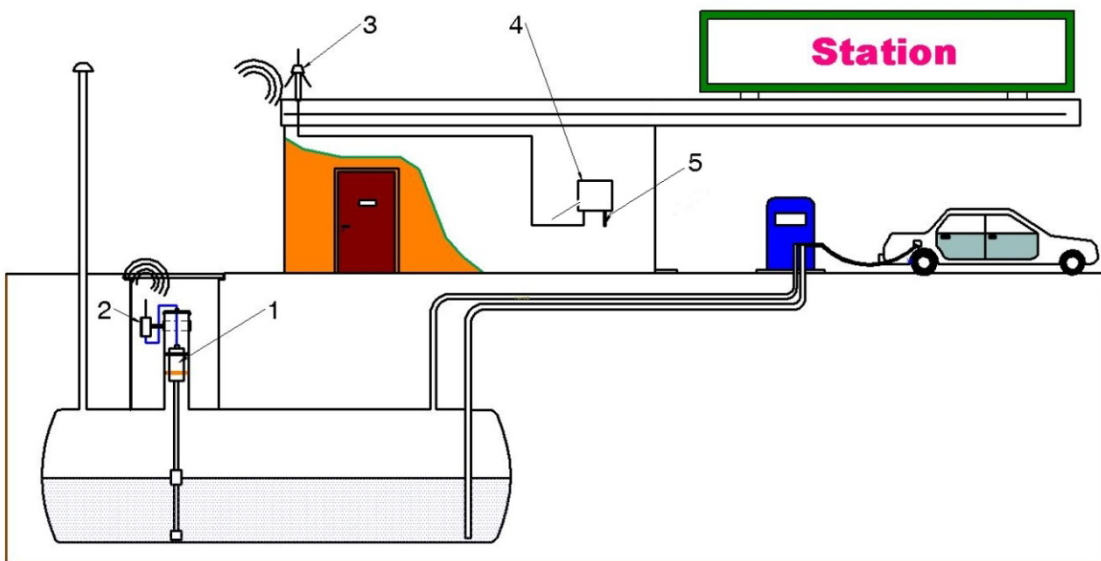

Figure 10: RF receiver module with directly connected receiver antenna

4.3.1 Antenna for the receiver

The external VISY-Antenna (Art. No. 900072) with spherical directional characteristic is supplied with a 2.5 m, 50 ohm coaxial cable.

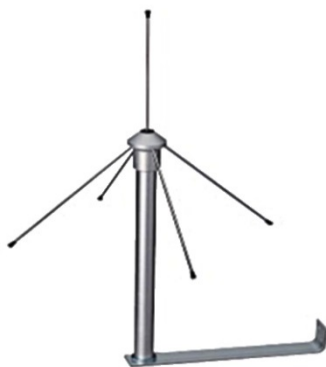

Figure 11 VISY-Antenna

The antenna can be mounted on a wall near the VISY-Command RF and positioned for optimum reception (see Figure 12).

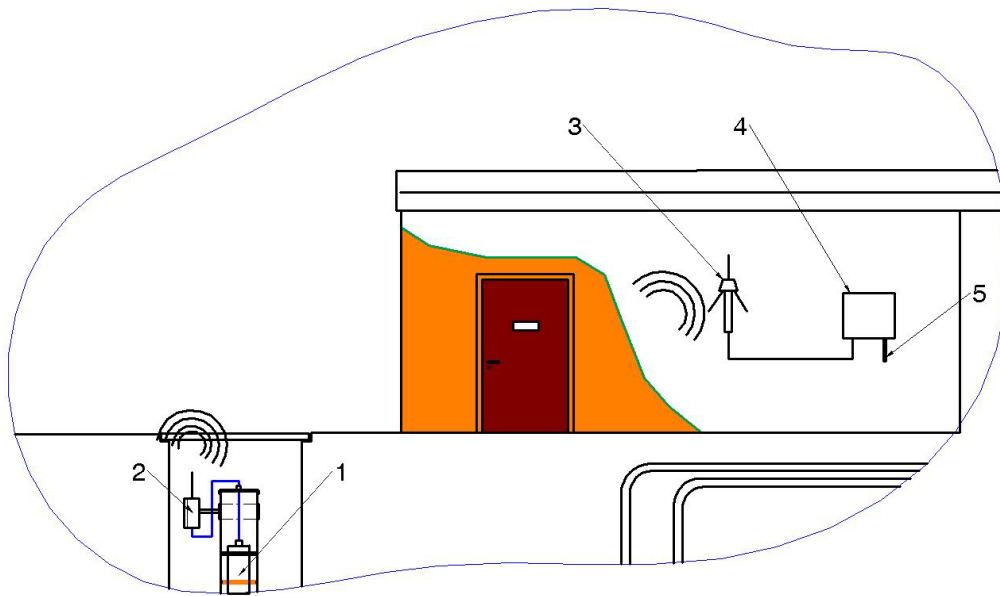

Figure 12: Receiving antenna with standard cable

If this is not enough, the antenna can be mounted inside or outside the building as close as possible to the VISY-RFT-L transmitter modules as shown in the diagram below (see Figure 13).

A coaxial cable extension may be required. The maximum permissible attenuation of the coaxial cable should not exceed 30 dB. To establish the connection, we recommend the use of the special 50 Ω low-attenuation antenna cable RG 213 (art. no.: 900082) with BNC crimp connector and adapter (art. no.: 900083).

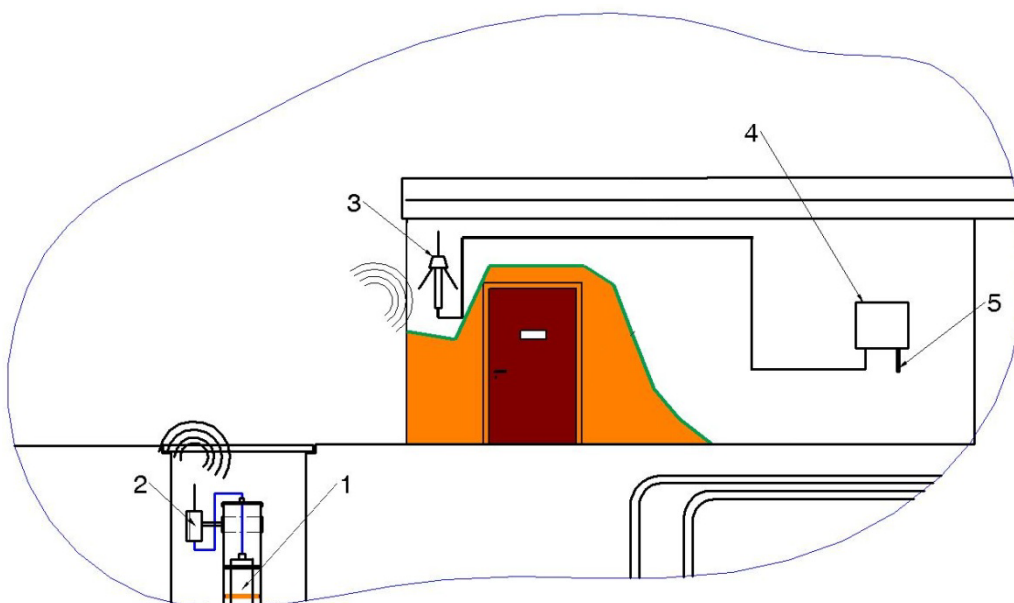

Figure 13: Receiving antenna with coaxial cable extension

The reception quality can be improved by a second receiving antenna. This additional antenna could, for example, be mounted on the petrol station building or canopy (see Figure 14).

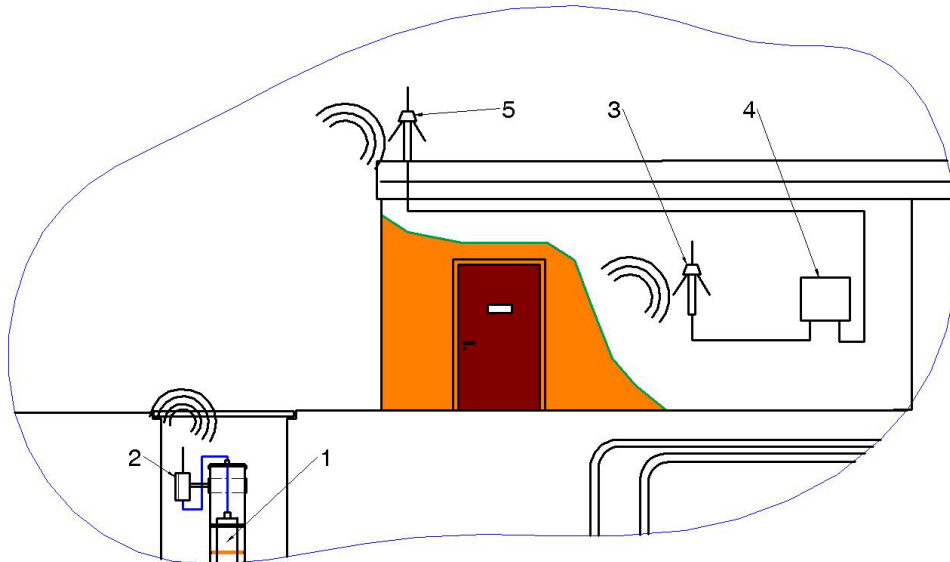

Figure 14: Two receiving antennas

5 Commissioning

5.1 VISY-RFT-L transmitter module

The VISY-RFT-L transmitter module features two modes of operation:

- Service mode
- Normal mode with two transmission intervals (every minute or every five minutes).



Pressing the button toggles between service mode and normal mode.

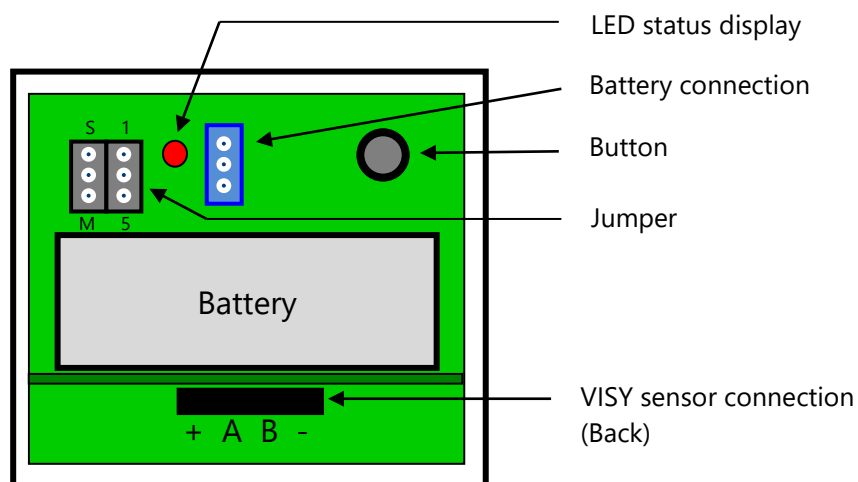
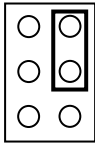

Figure 15: VISY-RFT-L transmitter module; schematic diagram without cover

5.1.1 Jumper setting

Transmission of data

1 minute Mode



5 minutes mode

(Factory setting)

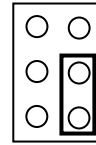

Transmits 3 data packets every minute Transmits 6 data packets every five minutes

Data protocol

Standard VISY TLG

(Factory setting)

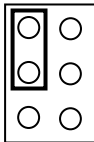

Multi Probe

1200 bps

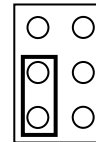

The setting of the data protocol must be the same for the VISY-RFT-L transmitter and the VISY-Command so that the data can be transferred. (See the technical documentation "VISY-Setup, art. no. 207158).

Data protocol "Multi Probe" (Prerequisites)



The "Multi Probe" data protocol is required for radio operation if the probes VISY-Stick Advanced, VISY-Density, VISY-Input, VISY-Output, or other VISY sensors, such as VISY-Stick Sump ... are used.

For the operation of the data protocol "Multi Probe 1200 bps", the following prerequisites exist:

- VI-4 Board: Firmware version \geq V4.2.1 (Control of the status display of the VI-4 board or with VISY-Setup)
- VISY-RFR: Firmware version \geq V 1.5.0 (control with the LEDs of the VISY-RFR)
- VISY-RFT-L: all device numbers \geq 5000 (control of the device numbers on the board), all transmitters must be set to the same data protocol.
- VISY-Stick: all device numbers of the probes \geq 20000 (control over the type plate)

5.1.2 Service mode

After the system has been fully installed, it is necessary to check the quality of radio transmission. To do so, set the VISY-RFT-L transmitter module to service mode by pressing the button. The locations of the button and LED indicator are shown in Figure 15. As soon as you have pressed the button, service mode is indicated by the LED lighting up for two seconds. In this operating mode, one data packet is transmitted every two to five seconds. These short radio transmission intervals make it easier to check and correct the position of the antennas for optimum reception. Before each radio transmission, the LED flashes depending on the status of the transmitter module (see Table 1).

After approximately 30 minutes, the VISY-RFT-L transmitter module quits service mode automatically and returns to normal mode.

The system normally has more than one VISY-RFT-L transmitter module installed. A collision of radio data packets is for the most part prevented by the VISY-RFT-L software.

5.1.3 Normal operation

In this operating mode, the values measured by the VISY-Sticks are transmitted either after one or after five minutes, depending on the position of the jumper (see section 5.1.1).

In the *1 minute mode*, the VISY-RFT-L transmitter module sends 3 identical radio data packets.

In the *5 minutes mode*, the VISY-RFT-L transmitter module sends 6 identical radio data packets.

The system normally has more than one VISY-RFT-L transmitter module installed. A collision of radio data packets is for the most part prevented by the VISY-RFT-L software.

5.1.4 Status code

LED flashes ...	VISY-RFT-L transmitter module status	VISY-Command RF status
1x	In operation	0
2x	No VISY sensor connected	9
3x	Communication error	8
4x	VISY sensor fault	1, 5, 6 or 7

Table 1: Status message of the VISY-RFT-L transmitter module

5.2 Procedure for checking the radio signal quality

The field strength of the transmitters can be checked directly by viewing the status of VISY-Command RF in the VISY-Setup software application (based on the age of measured values and field strength parameters) (see Figure 16).

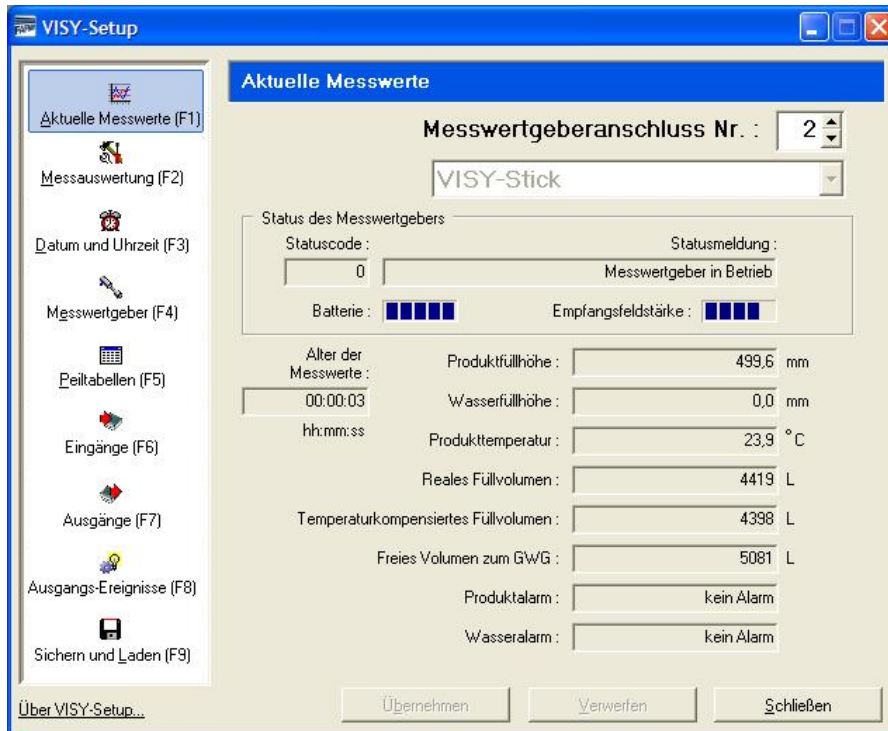

Figure 16: “Current Values” menu in VISY-Setup showing “Age of measured values”, “RF Field Strength” and “Battery”

If the RF Field Strength field is showing at least one bar, the system is working correctly.

Now start the first transmitter in service mode and close the cover on the manhole concerned. If the data are still being received, this means that the reception conditions for this transmitter are satisfactory. It is now possible to check the field strength using the VISY-RF Meter. An input sensitivity of -80 dBm is recommended, but a minimum input sensitivity of -97 dBm is required.

If a satisfactory field strength is not detected, the receiver antenna is sited too far away or it is too heavily shielded. In this event, it will be necessary to find a better position inside or outside the building using the VISY-RF Meter (see section 1.4).

Figure 10 to Figure 13 in section 4.3 show the various possibilities. At this stage, the receiver antenna should be secured only provisionally because the reception conditions vary for each underground tank and must be acceptable for **all** transmitters. Transmitters for which the minimum prerequisites are not fulfilled when the manhole cover is closed should be relocated inside the manhole or have their antenna alignment adjusted.

The potential for improving the quality of transmission from the manhole depends on the design (see section 4.2).

At the first attempt, the antenna should be fitted vertically (parallel to the receiver antenna). If the manhole has a metal cover, a horizontal antenna alignment may be more suitable. In this event, the horizontal antenna should always be aligned 90° to the line of sight first. Due to the abundance of possible reflections that occur inside an enclosed manhole, it may be that an antenna alignment angle other than 90° results in a stronger signal being received at the location of the receiver antenna.

- Masonry/concrete manhole with metal cover and frame: Due to the shielding effect of the metal cover, it may be better to site the transmitter deeper down the manhole. If this measure does not lead to any success, we recommend the use of an approved plastic cover.
- Manhole made of plastic tube with metal cover and metal tube in the upper part: Due to the shielding effect of the metal tube, the transmitter should be placed beneath the metal tube end. If this measure does not prove satisfactory, we recommend the use of an approved plastic cover.
- Manhole in welded steel with metal cover and frame:
Weaker signals from the manhole should be expected with this type of construction. One possible solution could be to replace the cover with an approved plastic cover. Another possibility would be to place the receiving antenna as close as possible to the transmitter antenna, i.e. on the canopy immediately above the cover, or to install the VISY-RFT-L transmitter module outside the manhole (Figure 18). If the desired effect is still not achieved, it will be necessary to route a cable.



If an extension to the connection cable is required, the junction joining the cable ends must be established safely, i.e. with protection against water ingress. We recommend the use of our IP68 TeeTube 4 pole end barrier connector (Art. No.: 910035), for example.



Figure 17 IP68 TeeTube 4 pole end barrier connector

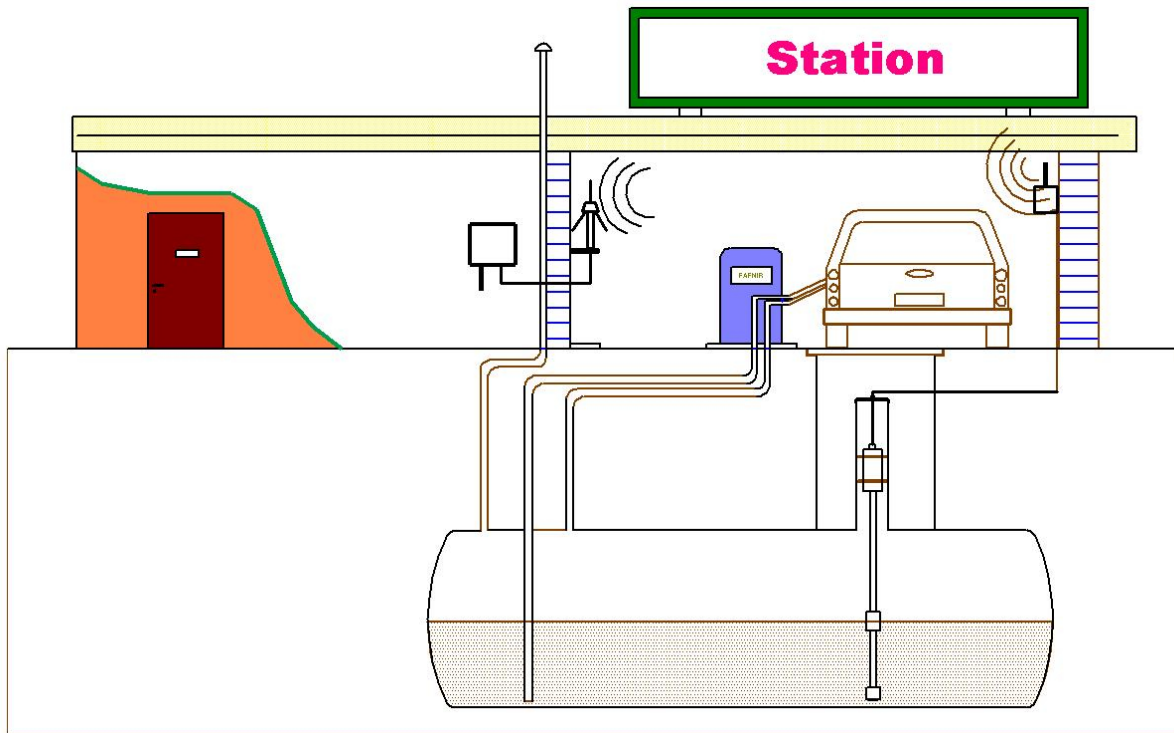



Figure 18: VISY-RFT-L transmitter module installed outside the manhole

-  *Reception quality can be seriously affected by the presence of ice and snow on the manhole cover.*
-  *Reception quality can be seriously affected if the line of sight between manhole and receiver antenna is blocked by a vehicle.*

The procedure described should help to achieve satisfactory transfer properties in the majority of cases. When the data transfer quality of each sensor has been checked, it is necessary to fix all components of the VISY-RF wireless system in their final position.

6 General notes and troubleshooting

6.1 Radio signal losses

Radio signals are influenced by the presence of objects along the propagation path. This must be taken into consideration when deciding on the optimum position for siting the antennas. Whenever a radio signal encounters an object, signal power is reduced because some of the signal is absorbed or reflected by the object and the wanted signal is weakened. This attenuation can vary with the type of object penetrated by the radio signal. Losses are significantly increased by objects that have a high metal content, for example.

- Price towers, dispensers, and other objects common to petrol stations, can lead to losses of 5 – 15 dB, depending on object size and material.
- Walls can cause losses of 10 – 30 dB, depending on type of construction.
- Bushes, trees or earth can be responsible for losses of 10 – 30 dB.

6.2 Radio line of sight

Radio line of sight refers to the clear, unimpeded signal path between transmitter and receiver. For the VISY-RF wireless system, the receiver antenna should be placed in direct line of sight to the manhole.

6.3 Interference radiation

Radio interference distorts or completely overlaps the received signal with the effect that it becomes impossible to evaluate. Interference radiation can be caused by devices nearby, e.g. transmitters on the same frequency.

6.4 Equipment location

The VISY-RFT-L transmitters should be mounted as high as possible in the manhole.

The receiver antenna should be installed in a position within direct line of sight of the manholes to enable unimpeded transfer of the radio signal. If possible, the antenna should be mounted in a corner to exploit the parabolic effect and improve reception.

6.5 Error codes and troubleshooting tips

The error codes below may be displayed by the VISY-Setup software application (see Figure 16). In VISY-Command RF, the same error codes are represented by the two 7-segment LED displays.

Error code	Description	Suggested solution
1-7	Problem with the VISY-Stick probe	See "VISY-Command" technical documentation
8	Bad connections between VISY-RFT-L and VISY-Stick	Check cable connections (M12 couplers)
9	No sensor connected to VISY-RFT transmitter	Check connections and functionality of the VISY sensors
10	No data available	Check connections inside VISY-Command RF between VISY-RFR and VI-Board
11	Communication fault	Check all components
13	Waiting for first data transfer	If the error is displayed permanently, check the entire installation and configuration.

Table 2: List of error codes

6.6 Battery

The status of the battery can be checked using VISY-View Touch or the software VISY-Setup (see Figure 16). Five bars indicate that the battery is fully charged. Even if only one bar is displayed for the battery, the battery should still have sufficient charge to last a few weeks. However, the next battery change should be scheduled immediately to prevent failure of the VISY-RFT-L transmitter. If no bars are displayed, the battery has completely expired.



Battery performance is temperature-dependent. The battery operates only in the temperature range of -40 to +60 °C.



The battery should be replaced if the display is reporting battery flat (≤ 1 bar).



It is permissible to replace the battery within the potentially explosive atmosphere (zone 1).



In the interests of explosion safety, only the use of original FAFNIR batteries (art. no. 900095) is permitted.



Separate collection:
The batteries must be disposed of as special waste.



7 Technical Data

7.1 General data

Frequency	433.92 MHz
Signal path (line of sight)	max. 250 m

7.2 VISY-RFT-L transmitter

Radio power output	+8 dBm
Antenna	Lambda ¼ antenna with M4 set screw
Battery pack	Lithium
Battery capacity	VISY-RFT-L2 = 19 Ah
Expected battery life-time at 20 °C ambient temperature and average tank filling of 30 minutes/day	
	4 years (5 minutes mode)
	2 years (1 minute mode)
Battery art. no.	900095
Housing	80 x 82 x 55 [mm]
Protection class	IP 67
Operating temperature range	-40 ... +60 °C

7.3 VISY-RFR receiver (in VISY-Command RF)

Sensitivity	-107 dBm
Antenna connection	2 x BNC
Supply voltage	230 VAC ±10 %; 50 – 60 Hz
Power:	1 W
Dimensions	137 x 75 x 52 [mm]



**EU-Konformitätserklärung
EU Declaration of Conformity
Déclaration UE de Conformité**

**FAFNIR GmbH
Schnackenburgallee 149 c
22525 Hamburg
Deutschland / Germany / Allemagne**

erklärt als Hersteller in alleiniger Verantwortung, dass das Produkt
declares as manufacturer under sole responsibility that the product
déclare sous sa seule responsabilité en qualité de fabricant que le produit

Funksender / Radio Transmitter / Émetteur radioélectrique

VISY-RFT-L

den Vorschriften der europäischen Richtlinien
complies with the regulations of the European directives
est conforme aux réglementations des directives européennes suivantes

2011/65/EU	Beschränkung der Verwendung bestimmter gefährlicher Stoffe in Elektro- und Elektronikgeräten	RoHS
2011/65/EU	Restriction of the use of certain hazardous substances in electrical and electronic equipment	RoHS
2011/65/UE	Limitation de l'utilisation de certaines substances dangereuses dans les équipements électriques et électroniques	RoHS
2014/34/EU	Geräte und Schutzsysteme zur bestimmungsgemäßen Verwendung in explosionsgefährdeten Bereichen	ATEX
2014/34/EU	Equipment and protective systems intended for use in potentially explosive atmospheres	ATEX
2014/34/UE	Appareils et systèmes de protection destinés à être utilisés en atmosphères explosibles	ATEX
2014/53/EU	Bereitstellung von Funkanlagen auf dem Markt und zur Aufhebung der Richtlinie 1999/5/EG	FAR
2014/53/EU	Making available on the market of radio equipment and repealing Directive 1999/5/EC	RED
2014/53/UE	Mise à disposition sur le marché d'équipements radioélectriques et abrogeant la directive 1999/5/CE	DER

durch die Anwendung folgender harmonisierter Normen entspricht
by applying the harmonised standards
par l'application des normes

**RoHS / RoHS / RoHS
ATEX / ATEX / ATEX**

**EN 50581:2012
EN 60079-0:2012 + A11:2013
EN 60079-11:2012
EN 300 220-2 V3.1.1**

FAR / RED / DER

Das Produkt ist bestimmt als Elektro- und Elektronikgerät der RoHS-
The product is determined as electrical and electronic equipment of RoHS
Le produit est déterminés comme des équipements électriques et électroniques de RoHS

Kategorie / Category / Catégorie

**IT- und Telekommunikationsgeräte
IT and telecommunications equipment
Équipements informatiques et de télécommunications**

Die notifizierte Stelle TÜV NORD CERT GmbH, 0044 hat eine EU-Baumusterprüfung durchgeführt und folgende Bescheinigung ausgestellt
The notified body TÜV NORD CERT GmbH, 0044 performed a EU-type examination and issued the certificate
L'organisme notifié TÜV NORD CERT GmbH, 0044 a effectué examen UE de type et a établi l'attestation

VISY-RFT-L

TÜV 07 ATEX 554018 X

Das Produkt entspricht dem FAR-Konformitätsbewertungsverfahren und den FAR-Anforderungen
The product complies with the RED conformity assessment procedure and the RED requirements
Le produit est conforme avec la procédure d'évaluation de la conformité DER et des exigences DER

**VISY-RFT-L
Sender / Transmitter / Émetteur**

**Modul A / Module A / Module A
Auslastungsgrad < 10 % / Duty cycle < 10 % / Cycle de service < 10 %**

Hamburg, 14.08.2017
Ort, Datum / Place, Date / Lieu, Date

Geschäftsführer / Managing Director / Gérant: René Albrecht



**EU-Konformitätserklärung
EU Declaration of Conformity
Déclaration UE de Conformité**

**FAFNIR GmbH
Schnackenburgallee 149 c
22525 Hamburg / Germany**

erklärt als Hersteller in alleiniger Verantwortung, dass das Produkt
declares as manufacturer under sole responsibility that the product
déclare sous sa seule responsabilité en qualité de fabricant que le produit

**Funkempfänger
Radio Receiver
Récepteur radioélectrique
VISY-RFR-D**

den Vorschriften der europäischen Richtlinien
complies with the regulations of the European directives
est conforme aux réglementations des directives européennes suivantes

2011/65/EU	Beschränkung der Verwendung bestimmter gefährlicher Stoffe in Elektro- und Elektronikgeräten	RoHS
2011/65/EU	Restriction of the use of certain hazardous substances in electrical and electronic equipment	RoHS
2011/65/UE	Limitation de l'utilisation de certaines substances dangereuses dans les équipements électriques et électroniques	RoHS
2014/30/EU	Elektromagnetische Verträglichkeit	EMV
2014/30/EU	Electromagnetic compatibility	EMC
2014/30/UE	Compatibilité électromagnétique	CEM
2014/35/EU	Bereitstellung elektrischer Betriebsmittel zur Verwendung innerhalb bestimmter Spannungsgrenzen auf dem Markt	NSRL
2014/35/EU	Making available on the market of electrical equipment designed for use within certain voltage limits	LVD
2014/35/UE	Mise à disposition sur le marché du matériel électrique destiné à être employé dans certaines limites de tension	DBT
2014/53/EU	Bereitstellung von Funkanlagen auf dem Markt und zur Aufhebung der Richtlinie 1999/5/EG	FAR
2014/53/EU	Making available on the market of radio equipment and repealing Directive 1999/5/EC	RED
2014/53/UE	Mise à disposition sur le marché d'équipements radioélectriques et abrogeant la directive 1999/5/CE	DER

durch die Anwendung folgender harmonisierter Normen entspricht
by applying the harmonised standards
par l'application des normes

RoHS / RoHS / RoHS	EN 50581:2012
EMV / EMC / CEM	ETSI EN 300 220-1 V2.4.1
NSRL / LVD / DBT	EN 61010-1:2010
FAR / RED / DER	ETSI EN 300 220-2 V2.4.1

Das Produkt ist bestimmt als Elektro- und Elektronikgerät der RoHS-
The product is determined as electrical and electronic equipment of RoHS
Le produit est déterminés comme des équipements électriques et électroniques de RoHS

Kategorie / Category / Catégorie **Überwachungs- und Kontrollinstrumenten in der Industrie /
Industrial Monitoring and Control Instruments /
Instruments de contrôle et de surveillance industriels**

Das Produkt entspricht den EMV-Anforderungen
The product complies with the EMC requirements
Le produit est conforme aux exigences CEM

Empfänger / Receiver / Récepteur **Kategorie 2 / Category 2 / Catégorie 2**

Das Produkt entspricht dem NSRL- und FAR Konformitätsbewertungsverfahren
The product complies with the LVD and RED conformity assessment procedure
Le produit est conforme avec la procédure d'évaluation DBT et DER de la conformité

VISY-RFR-D **Modul A / Module A / Module A**

Hamburg, 13.06.2016
Ort, Datum / Place, Date / Lieu, Date

Geschäftsführer / Managing Director / Gérant: René Albrecht

Translation

(1) **EU-Type Examination Certificate**

- (2) Equipment and protective systems intended for use in potentially explosive atmospheres, **Directive 2014/34/EU**



- (3) **Certificate Number** TÜV 07 ATEX 554018 X **issue:** 00
- (4) for the product: Radio Transmitter type VISY-RFT-L
- (5) of the manufacturer: **FAFNIR GmbH**
- (6) Address: Schnackenburgallee 149 c, 22525 Hamburg, Germany
- Order number: 8000468089
- Date of issue: 2017-07-28

- (7) The design of this product and any acceptable variation thereto are specified in the schedule to this EU-Type Examination Certificate and the documents therein referred to.

- (8) The TÜV NORD CERT GmbH, Notified Body No. 0044, in accordance with Article 17 of the Directive 2014/34/EU of the European Parliament and the Council of 26 February 2014, certifies that this product has been found to comply with the Essential Health and Safety Requirements relating to the design and construction of products intended for use in potentially explosive atmospheres given in Annex II to the Directive.

The examination and test results are recorded in the confidential ATEX Assessment Report No. 17 203 193457.

- (9) Compliance with the Essential Health and Safety Requirements has been assured by compliance with:

EN 60079-0:2012 + A11:2013 **EN 60079-11:2012**

except in respect of those requirements listed at item 18 of the schedule.

- (10) If the sign "X" is placed after the certificate number, it indicates that the product is subject to the Specific Conditions for Use specified in the schedule to this certificate.
- (11) This EU-Type Examination Certificate relates only to the design, and construction of the specified product. Further requirements of the Directive apply to the manufacturing process and supply of this equipment. These are not covered by this certificate.

- (12) The marking of the product shall include the following:

 **II 1 G Ex ia IIC T4 Ga**

TÜV NORD CERT GmbH, Langemarckstraße 20, 45141 Essen, notified by the central office of the countries for safety engineering (ZLS), Ident. Nr. 0044, legal successor of the TÜV NORD CERT GmbH & Co. KG Ident. Nr. 0032

The head of the notified body



Andreas Meyer

Hanover office, Am TÜV 1, 30519 Hannover, Tel. +49 511 998-61455, Fax +49 511 998-61590

Schedule to EU-Type Examination Certificate No. TÜV 07 ATEX 554018 X issue 00

(16) Drawings and documents are listed in the ATEX Assessment Report No. 17 203 193456.

(17) Specific Conditions for Use

The radio transmitter is built in a plastic enclosure. The risk of ignition by static electricity due to friction on the enclosure has to be avoided. The equipment shall be cleaned only with damp or antistatic cloth.

(18) Essential Health and Safety Requirements

no additional ones

- End of Certificate -

8.4 Operating Instructions VISY-RFT-L...

Operating Instructions according to Directive 2014/34/EU TÜV 07 ATEX 554018 X

Wireless transmitter type VISY-RFT-L

Status: 07.2017

I Range of application

The VISY-RFT-L radio transmitter is an intrinsically safe device for transmitting data of level measurements in potentially explosive atmospheres. The radio transmitter is operated with a replaceable battery unit.

II Standards

The radio transmitter is designed in accordance with the following European standards

EN 60079-0:2012 + A11:2013	Equipment - General requirements
EN 60079-11:2012	Equipment protection by intrinsic safety "i"

III Instructions for safe ...

III.a ... use

The radio transmitter serves as intrinsically safe equipment and is suitable for use in potentially explosive area (Zone 0). The intrinsically safe sensor circuit can be installed in Ex Zone 0 and is suitable for all gas groups (IIA, IIB and IIC).

The approval applies to the device version VISY-RFT-L with the battery unit "L0", "L1" or "L2".

III.b ... assembling and dismantling

To install the radio transmitter or make changes to it such as changing the battery unit, it is necessary to disassemble the upper housing part from the lower housing part. To do this, loosen the four screws on the upper housing part. After the work, the housing must be closed again with the four screws.

III.c ... Installation

Special rules and regulations, including EN 60079-14 and local installation regulations, must be observed.

The radio transmitter is suitable for wall mounting. In order to reach the mounting holes, the housing must be dismantled.

For the wiring (preferably blue cable) from the radio transmitter to the sensor, the permissible inductance and capacitance under item V must not be exceeded.

III.d ... adjustment

No Ex-relevant equipment is required for operating the radio transmitter.

III.e ... putting into service

Before putting into service, all devices must be checked of right connection and fitting.

III.f ... maintenance (servicing and emergency repair)

The radio transmitter is generally maintenance-free. In case of a defect, it must be send back to FAFNIR or one of its representations.

Warning: The cleaning of the housing must only be carried out with a damp cloth.

There is compliance with the requirements for the dielectric strength between the intrinsically safe circuit and the chassis of the radio transmitter in accordance with EN 60079-11, section 6.3.13.

Only FAFNIR battery units (L0, L1 or L2) may be used when replacing the battery unit. Replacing the battery unit does not require the exclusion of an explosive atmosphere.

IV Device marking

1	Manufacturer:	FAFNIR GmbH, 22525 Hamburg
2	Type designation:	VISY-RFT-L
3	Certificate number:	TÜV 07 ATEX 554018 X
4	Ex marking:	⊕ II 1 G Ex ia IIC T4 Ga
5	Warning label:	WARNING – Potential electrostatic charging hazard – See instructions
6	CE marking:	CE 0044
7	Battery using:	Use only replaceable battery pack FAFNIR L0, L1 or L2
8	Technical Data	See instructions for technical data

Additionally the battery unit is characterized as follows:

1	Manufacturer:	FAFNIR GmbH, 22525 Hamburg
2	Type designation:	L0, L1 or L2
3	Use:	Use only on VISY-RFT-L

V Technical data

Only the FAFNIR battery units L0, L1 or L2 may be used as auxiliary energy for the radio transmitter!

The electric circuit of the sensor is designed with "intrinsic safety" (ia) ignition protection class with a linear output characteristic. The output values are:

Output voltage	$U_o \leq 7,8 \text{ V}$
Output current	$I_o \leq 59 \text{ mA}$
Output power	$P_o \leq 98 \text{ mW}$
Internal inductance	L_i negligibly small
Internal capacitance	C_i negligibly small

The permissible external inductance and capacitance are:

	IIC		IIB	
$L_o \leq$	10 mH	5 mH	50 mH	20 mH
$C_o \leq$	690 nF	950 nF	2.6 μF	4 μF

The maximum values of the parameter pairings may simultaneously be used as concentrated capacitance and concentrated inductance.

The maximum temperature is:

Ambient temperature:	$T_a = -40 \text{ }^\circ\text{C} \dots +60 \text{ }^\circ\text{C}$
----------------------	---

For use in category 1G:

The process pressure for the media must be between 0.8 bar and 1.1 bar where explosive vapour-air mixtures are present. If no explosive mixtures are present, the equipment may also be operated outside this area according to the manufacturer's specification.

General information (see also EN 60079-0, section 1):

Zone 0 exists only under atmospheric conditions:

Temperature range:	20 $^\circ\text{C}$... +60 $^\circ\text{C}$
Pressure range:	0.8 bar ... 1.1 bar
Oxidants:	Air (oxygen content approx. 21 %)

The radio transmitter achieves a housing protection degree of:

Degree of protection:	$\leq \text{IP66}$
-----------------------	--------------------

VI Special conditions for use

The radio transmitter is built in a plastic housing. The risk of ignition by static electricity due to friction on the housing is to be avoided.

8.5 List of figures

Figure 1: VISY-RF Meter	3
Figure 2 Typical layout of a petrol station	5
Figure 3: manhole with plastic cover	6
Figure 4: walled manhole with metal cover	6
Figure 5: welded (metal) manhole with metal cover	6
Figure 6: manhole with metal ring and metal cover	7
Figure 7: manhole with plastic cover	7
Figure 8 Installation Kit VISY-RFT	8
Figure 9: VISY-RFT-L transmitter module with cover removed	9
Figure 10: RF receiver module with directly connected receiver antenna.....	10
Figure 11 VISY-Antenna.....	10
Figure 12: Receiving antenna with standard cable	11
Figure 13: Receiving antenna with coaxial cable extension.....	11
Figure 14: Two receiving antennas	12
Figure 15: VISY-RFT-L transmitter module; schematic diagram without cover	12
Figure 16: "Current Values" menu in VISY-Setup	15
Figure 17 IP68 TeeTube 4 pole end barrier connector.....	16
Figure 18: VISY-RFT-L transmitter module installed outside the manhole	17

8.6 Tables

Table 1: Status message of the VISY-RFT-L transmitter module	14
Table 2: List of error codes	19

Blank Page



Blank Page

Blank Page



FAFNIR GmbH
Schnackenburgallee 149 c
22525 Hamburg, Germany
Tel.: +49/40/39 82 07-0
Fax: +49/40/390 63 39
E-mail: info@fafnir.com
Web: www.fafnir.com
