

VISY-ICI 485

**Communications adapter for connecting VISY-Input 8
and VISY-Output 4 to VISY-Command**

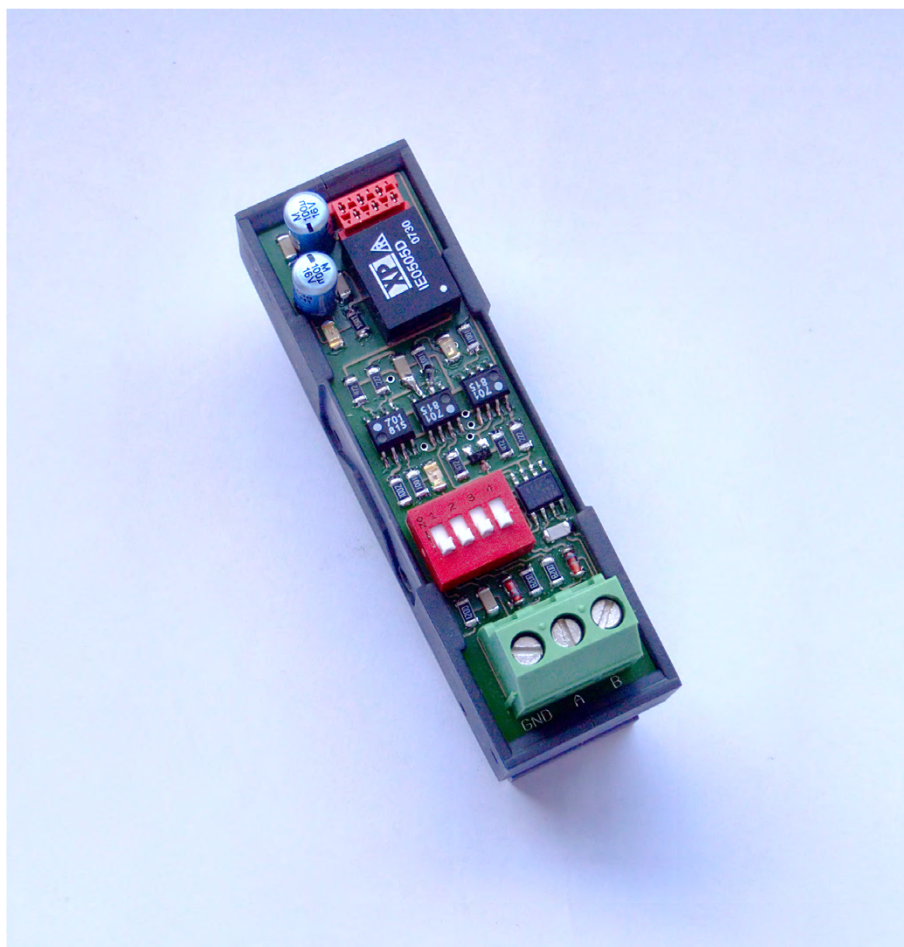

Release: 2016-09
Revision: 1
Article No.: 207150



Table of Contents

1	Introduction	4
2	Installation	4
2.1	Safety precautions.....	4
2.2	Assembly	5
2.3	Connections, LEDs and DIP switch	6
2.4	Connection to the VI-... interface card.....	6
2.5	Connecting VISY-Input 8 / VISY-Output 4.....	7
2.6	Power supply LED.....	8
2.7	Communication LEDs.....	8
3	Configuration	9
3.1	RS-485 network – bias and termination.....	9
3.2	Reference to more detailed instructions.....	9
4	Technical data	10
5	List of figures	10
6	List of tables.....	10
7	Appendix	11
7.1	EC Declaration of Conformity.....	11

© Copyright:

Reproduction and translation only with the written consent of the FAFNIR company.
FAFNIR reserves the right to carry out product alterations without prior notice.

1 Introduction

The VISY-ICI 485 is a communications adapter to connect VISY-Input 8 and VISY-Output 4 components to the VISY-Command.

The connection is established by an RS-485 interface. The interface is galvanically isolated from the rest of the circuit, and therefore from the VI-... interface card, by optocouplers and a DC/DC converter. Galvanic isolation improves the reliability of the communication.

For a convenient integration into VISY-Command, the printed circuit board (PCB) of the VISY-ICI 485 is mounted on a module carrier for subsequent installation on DIN rails.

2 Installation

2.1 Safety precautions

The following safety precautions must be observed during installation of the VISY-ICI 485 communications adapter:

- The VISY-ICI 485 is designed for operation only with the VI-... interface card.
- Modifications to the VISY-ICI 485 are prohibited without the prior consent of the manufacturer.
- The installation and configuration of the VISY-ICI 485 communications adapter must be carried out only by expert, authorised personnel. Specialised knowledge must be obtained by regular training.
- Operators, installers and service technicians must comply with all applicable safety regulations. This also applies to any local safety regulations and accident prevention regulations not stated in this technical documentation.

The safety instructions in this manual are labelled as follows:



If you do not observe these safety instructions, the risk of an accident exists or the VISY-X system could be damaged.



Useful information in these instructions, that should be observed, is printed in italics and marked with this symbol.

2.2 Assembly

The VISY-ICI 485 is designed to be mounted on the DIN rail only.

Hold the module carrier of the VISY-ICI 485 at an angle to the rail and fit the mounting foot onto the rail in such a way that one side of the module carrier is secured. Then press the other side of the module carrier onto the rail until this side snaps into place and the module carrier is firmly locked.

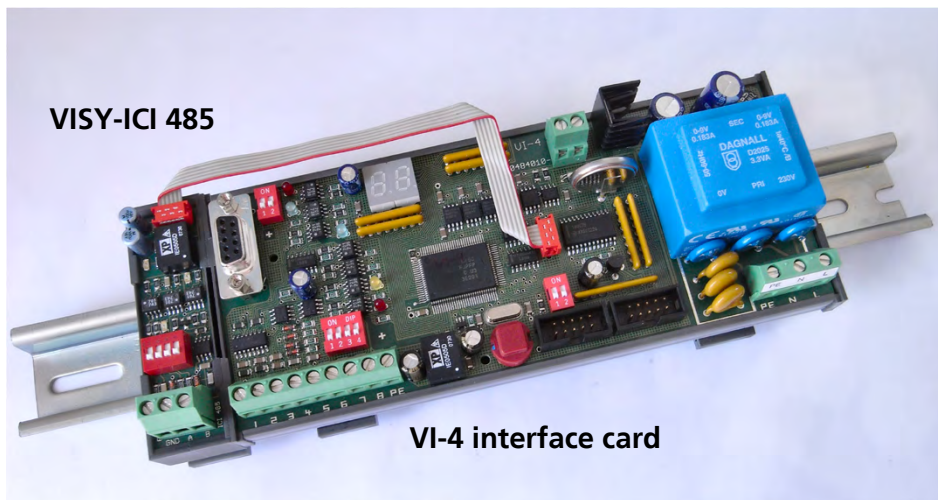

Figure 1: Assembly



The VISY-ICI 485 can be used only in conjunction with the VI-... interface card (version VI-4 or later).



Mount the VISY-ICI 485 to the left of the VI-... interface card on the DIN rail.



The module carrier can be released from the DIN rail only by prising out the mounting foot with a screwdriver.

2.3 Connections, LEDs and DIP switch

The VISY-ICI 485 has one connection for power supply and communication and another one for connecting VISY-Input 8 and VISY-Output 4. Operating states are indicated by three light-emitting diodes (LEDs). The connections and LEDs are arranged as follows:

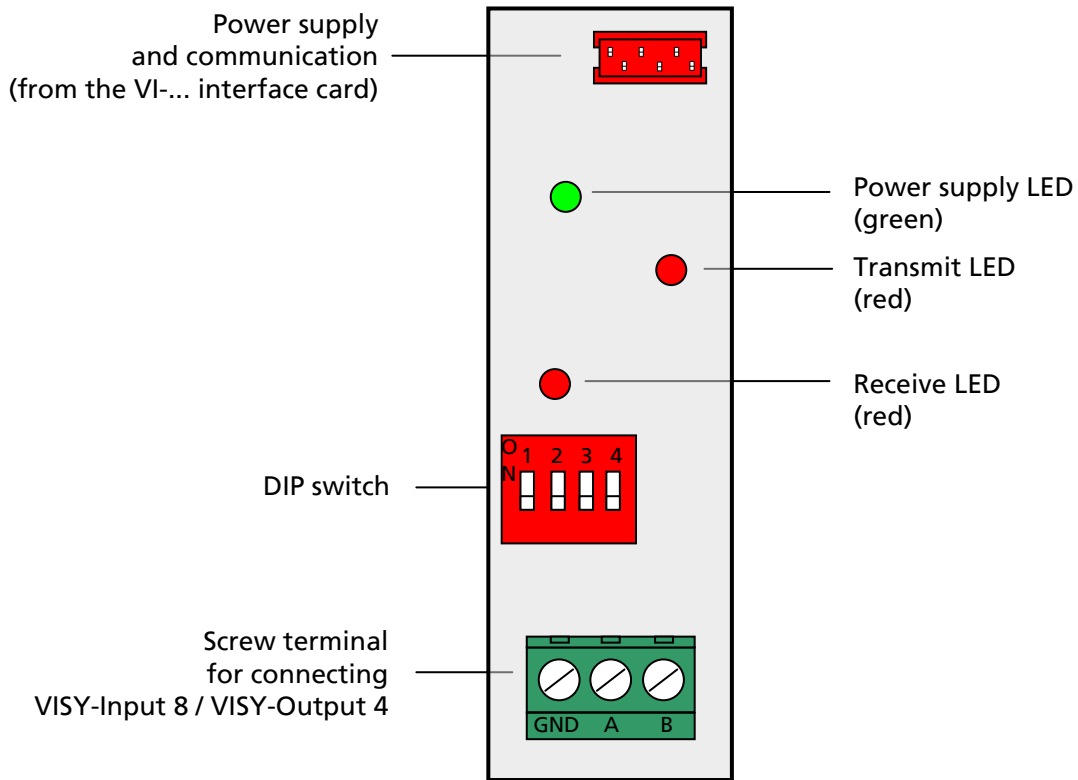

Figure 2: Connections, LEDs and DIP switch

2.4 Connection to the VI-... interface card

Connect the VISY-ICI 485 to the VI-... interface card using the 6-pole ribbon cable supplied (see Fig. 1). This ribbon cable provides the power supply and the data communication link to the VISY-ICI 485.

2.5 Connecting VISY-Input 8 / VISY-Output 4

The VISY-ICI 485 supports the simultaneous operation of up to eight VISY-Input 8 and eight VISY-Output 4 components. The components are connected to terminal A, B and GND of the 3-pole screw terminal (galvanically isolated interface). An RS-485 network is formed when the components are operated in conjunction with the VI... interface card (also connected to the VISY-ICI 485). The optimum configuration for the RS-485 network is a linear topology (daisy chaining of all network subscribers). Ring or star topologies should be avoided.

For the wiring of VISY-Input 8 / VISY-Output 4 components, a 3-core cable including signal ground (GND) is recommended in order to improve immunity to interference.

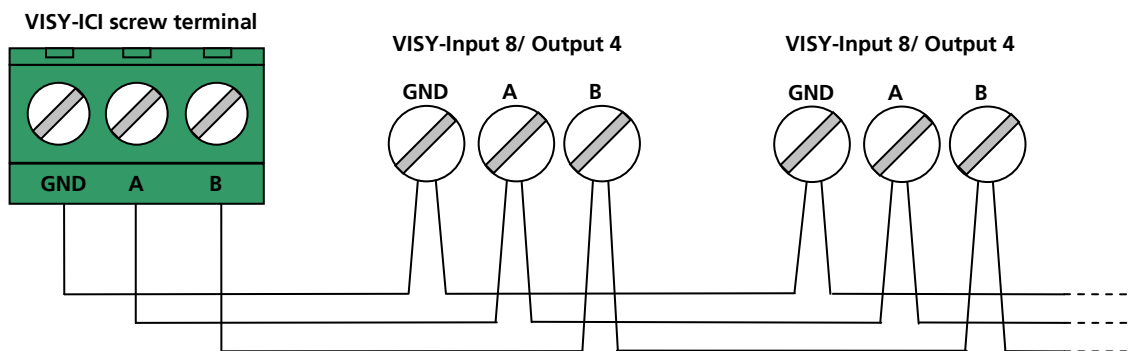

Figure 3: Connecting VISY-Input 8 / VISY-Output 4

If shielded lines are used, the shield should be placed on the PE connection to prevent interference coupling. If the shield cannot be fitted on both sides, it is possible to work with a shield fitted to one side in the VISY-Command.



If shielded lines are used, do not place the line shield on signal ground (GND).



Please note that the longer the line length, the greater the probability of equipotential currents flowing through a line shield earthed on both sides. Where necessary, an additional equipotential bonding conductor must be provided between the connected devices in accordance with local rules and regulations.

2.6 Power supply LED

The power supply LED lights up green whenever the VISY-ICI 485 is being supplied with power. For location, see Fig. 2.

LED (green)	Meaning
on	VISY-ICI 485 supplied with power
off	VISY-ICI 485 not supplied with power

Table 1: Power supply LED

2.7 Communication LEDs

The two communication LEDs light up red whenever data are being transmitted or received. For locations, see Fig. 2.

LED (red)	Meaning
on	Transmitting/receiving data
off	Not transmitting/receiving data

Table 2: Communication LEDs

3 Configuration

3.1 RS-485 network – bias and termination

Using the DIP switches, it is possible to bias the communication lines with a defined rest potential and activate the terminating impedances.

By default, a bias is applied to the RS-485 network in order to improve reliability of communication.

Under normal circumstances, communication in the RS-485 network should be troublefree without the need for terminating impedance activation because the data rate is relatively low.

The following table shows the possible functions depending on DIP switch configuration:

DIP switch				Function
1	2	3	4	
OFF	OFF	OFF	OFF	no termination and no bias
ON	OFF	OFF	OFF	with series termination 120 Ω / 100 nF
ON	OFF	OFF	ON	with termination resistance 120 Ω
OFF	ON	ON	OFF	with bias (factory default)
ON	ON	ON	OFF	with series termination 120 Ω / 100 nF and bias
ON	ON	ON	ON	with termination resistance 120 Ω and bias

Table 3: DIP switch



All switch positions not shown in the table are unauthorised and will result in communication faults.

3.2 Reference to more detailed instructions

As is customary for the VISY-X System, all VISY-Input 8 / VISY-Output 4 components to be connected need to be configured using the VISY-Setup configuration software. You will find detailed information of the components and their configuration in the following instruction manuals:

- Technical Documentation VISY-Setup 4 (English) – Art. No. 207158
- Technical Documentation VISY-Input 8 (English) – Art. No. 207166
- Technical Documentation VISY-Output 4 (English) – Art. No. 207131

4 Technical data

Ambient temperature:	0 °C to +40 °C
Power supply:	5 V _{DC} , ≤ 35 mA (from the VI-... interface card), connection cable included
Serial interface:	RS-485, galvanically isolated, 3-pole screw terminal with signal ground (GND), for connecting VISY-Input 8 / VISY-Output 4
Operation indicator:	green LED
Communication indicator:	red LEDs: one for transmit, one for receive
Housing:	module carrier for mounting on DIN rails
Dimensions:	h 76 x w 24 x d 47 [mm]

5 List of figures

Figure 1: Assembly.....	5
Figure 2: Connections, LEDs and DIP switch.....	6
Figure 3: Connecting VISY-Input 8 / VISY-Output 4	7

6 List of tables

Table 1: Power supply LED	8
Table 2: Communication LEDs.....	8
Table 3: DIP switch.....	9



**EU-Konformitätserklärung
EU Declaration of Conformity
Déclaration UE de Conformité**

**FAFNIR GmbH
Bahrenfelder Straße 19
22765 Hamburg / Germany**

erklärt als Hersteller in alleiniger Verantwortung, dass das Produkt
declares as manufacturer under sole responsibility that the product
déclare sous sa seule responsabilité en qualité de fabricant que le produit

**Kommunikationsadapter
Communications Adapter
Adaptateur de communication**

VISY-ICI

den Vorschriften der europäischen Richtlinien
complies with the regulations of the European directives
est conforme aux réglementations des directives européennes suivantes

2011/65/EU	Beschränkung der Verwendung bestimmter gefährlicher Stoffe in Elektro- und Elektronikgeräten	RoHS
2011/65/EU	Restriction of the use of certain hazardous substances in electrical and electronic equipment	RoHS
2011/65/UE	Limitation de l'utilisation de certaines substances dangereuses dans les équipements électriques et électroniques	RoHS
2014/30/EU	Elektromagnetische Verträglichkeit	EMV
2014/30/EU	Electromagnetic compatibility	EMC
2014/30/UE	Compatibilité électromagnétique	CEM

durch die Anwendung folgender harmonisierter Normen entspricht
by applying the harmonised standards
par l'application des normes

**RoHS / RoHS / RoHS
EMV / EMC / CEM**

**EN 50581:2012
EN 61326-1:2013**

Das Produkt ist bestimmt als Elektro- und Elektronikgerät der RoHS-
The product is determined as electrical and electronic equipment of RoHS
Le produit est déterminés comme des équipements électriques et électroniques de RoHS

Kategorie / Category / Catégorie

**Überwachungs- und Kontrollinstrumenten in der Industrie /
Industrial Monitoring and Control Instruments /
Instruments de contrôle et de surveillance industriels**

Das Produkt entspricht den EMV-Anforderungen
The product complies with the EMC requirements
Le produit est conforme aux exigences CEM

**Störaussendung / Emission / Émission
Störfestigkeit / Immunity / D'immunité**

**Klasse B / Class B / Classe B
Industrielle elektromagnetische Umgebung /
Industrial electromagnetic environment /
Environnement électromagnétique industriel**

Hamburg, 20.04.2016
Ort, Datum / Place, Date / Lieu, Date

Geschäftsführer / Managing Director / Gérant: René Albrecht



FAFNIR GmbH
Schnackenburgallee 149 c
22525 Hamburg
Germany
Tel.: +49 / 40 / 39 82 07-0
Fax: +49 / 40 / 390 63 39
E-mail: info@fafnir.com
Web: www.fafnir.com
