

TORRIX M12

The magnetostrictive level sensor with PC configuration



Edition: 2023-05
Version: 7
Article no.: 350164

Table of Contents

1	Characteristics	1
2	Safety Instructions	2
3	Design and Function	3
3.1	TORRIX M12 versions.....	4
4	Mounting	5
4.1	Mounting with screw-in unit.....	6
4.2	Mounting with flange	7
4.3	Mounting with Bypass.....	7
5	Electrical connection	9
5.1	Connection Diagrams.....	10
5.1.1	Wiring diagram TORRIX C.....	10
5.1.2	Wiring diagram TORRIX Ex C	10
5.1.3	Wiring diagram TORRIX RS485	11
5.1.4	Wiring diagram TORRIX Ex RS485.....	11
5.1.5	Wiring diagram TORRIX (Ex) SC	12
5.2	Connection cable.....	12
5.3	Length of the connection cable (TORRIX 4 ... 20 mA variants).....	13
5.4	Wiring	14
6	Adjustment	15
6.1	TORRIX (Ex) C configuration.....	15
6.1.1	Failure mode	15
6.2	TORRIX (Ex) SC configuration	16
6.2.1	Failure mode	16
6.3	TORRIX (Ex) RS485 configuration.....	16
7	Maintenance	16
7.1	Servicing	16
7.2	Return Shipment.....	16
8	Technical Data	17
8.1	Sensor.....	17
8.2	Floats.....	18

9	List of Figures	19
10	Annex	20
10.1	EU Declaration of Conformity	20
10.2	EU-Type Examination Certificate	21
10.3	Instructions	29
10.4	SIL 2 Certificate	36
10.5	SIL 2 Safety Manual	40
10.6	Petroleum & Explosives Safety Organisation (PESO) Approval	45

© Copyright:

Reproduction and translation are permitted solely with the written consent of the FAFNIR GmbH. The FAFNIR GmbH reserves the right to carry out product alterations without prior notice.

1 Characteristics

The TORRIX M12 is a high-precision level sensor for continuous level and interface measurement of liquids in containers. The measuring principle of the sensor uses the physical effect of the magnetostriction and is largely unaffected by the temperature. This method is particularly ideal where level measurements are required to be extremely accurate, such as in the chemical industry.

This documentation describes the TORRIX M12 probe with connector M12 on the probe head cover. Another version is the TORRIX 5.5 with cable connection on the side of the probe head, see:



Technical documentation TORRIX, art. no. 350335

The TORRIX M12 is available for installation in containers with a screw-in body or with a flange, or for installation outside the containers in a bypass version. Probe lengths are possible from 100 mm to 6 m, as Flex version up to 22 m, as well as versions for different temperature and pressure ranges.

There are TORRIX versions with different interfaces available,

like following versions:

- TORRIX (HART) C: with 4 ... 20 mA output signal, optionally with digital output signal as HART® protocol, parametrisation via PC, media-contacting probe tube made of stainless steel
- TORRIX SC: with FAFNIR protocol for FAFNIR interface, media-contacting probe tube made of stainless steel
- TORRIX RS485: with Modbus ASCII or FAFNIR Universal Device Protocol, media-contacting probe tube made of stainless steel
- TORRIX ... FLEX: with all interfaces, media-contacting probe tube (flexible) made of stainless steel
- TORRIX ... VT: vibration-resistant version, with all interfaces, media-contacting probe tube made of stainless steel

For information about the TORRIX Flex installation, see:



TORRIX Flex Installation Guide multilingual, art. no. 350118

The TORRIX Sensors can also be supplied in Ex version:

The TORRIX Ex ... level sensor with Ex approval (ATEX, IECEx) can be installed in potentially explosive areas which require protection level Ga (Ex Zone 0), Ga/Gb (Ex Zone 0/1) or Gb (Ex Zone 1) for electrical equipment.

2 Safety Instructions

The TORRIX is used for level and interface measurement of liquids in containers. Only use the sensor for this purpose. The manufacturer accepts no liability for any form of damage resulting from improper use. Observe and follow all safety notes and the operating instructions.

The level sensor has been developed, manufactured and tested in accordance with the latest good engineering practices and generally accepted safety standards. Nevertheless, hazards may arise from its use. Observe the following safety instructions:

- Do not change or modify the level sensor or add any equipment without the prior consent of the manufacturer.
- The installation, operation and maintenance of the level sensor only be carried out by expert personnel. Specialised knowledge must be acquired by regular training.
- Operators, installers and service technicians must comply with all applicable safety regulations. This also applies to any local safety and accident prevention regulations which are not stated in this guide.

Special instructions are indicated in this manual with the following symbols:



If these safety instructions are not observed, it may result in the risk of accident or damages.



Useful information which ensures continued and correct operation of the equipment and makes your work easier.

REACH Regulation



The TORRIX sensors contain a lead-titanium-zirconium-oxide, which belongs to the substances of very high concern (SVHC) according to Regulation (EG) No. 1907/2006 (REACH). A corresponding note can be found on our website at: www.fafnir.com.

3 Design and Function

The level sensors consist of a probe head (1) and a probe tube (4) made of stainless steel. On the probe tube is a screw-in unit (3) (cutting ring fitting or ferrule fitting) for height-adjustable mounting in the container or a flange for fixed installation or the probe tube is mounted outside the container on a Bypass. A float (5) moves on the probe tube or in the Bypass for continuous measurement of the product fill level and optionally another float (6) for a continuous interface measurement.

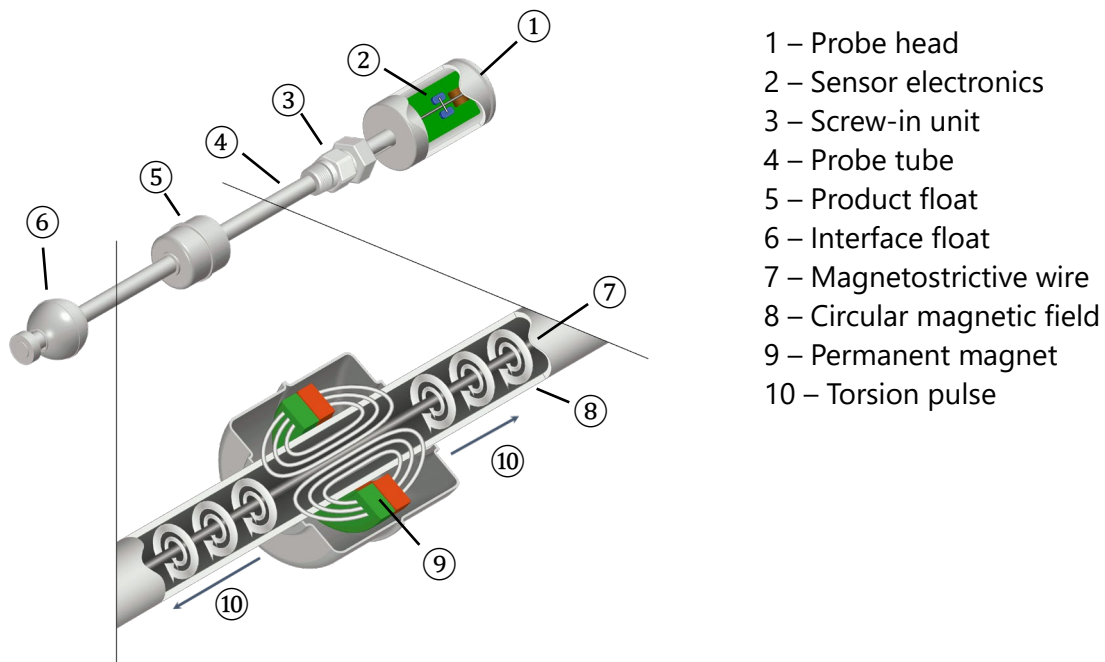

Figure 1: How the magnetostrictive measuring principle works

The sensor operates according to the magnetostrictive measuring principle. The probe tube contains a wire (7) made of magnetostrictive material. The sensor electronics (2) transmit pulses through the wire, which generate a circular magnetic field (8). Permanent magnets (9) are used as filling level sensors which are installed in both the product float (5) and the interface float (6). The magnetic field of the float magnets (9) axially magnetises the wire in this area. The superposition of the two magnetic fields produces a torsional wave (10) at the float position, which then propagates along the wire in both directions. One torsion pulse runs directly to the probe head and the other one is reflected at the bottom end of the probe tube. The time between the current pulse being transmitted and the two torsion pulses arriving at the probe head is measured and the float position calculated. The position of the interface float is calculated by measuring a second pulse.

3.1 TORRIX M12 versions

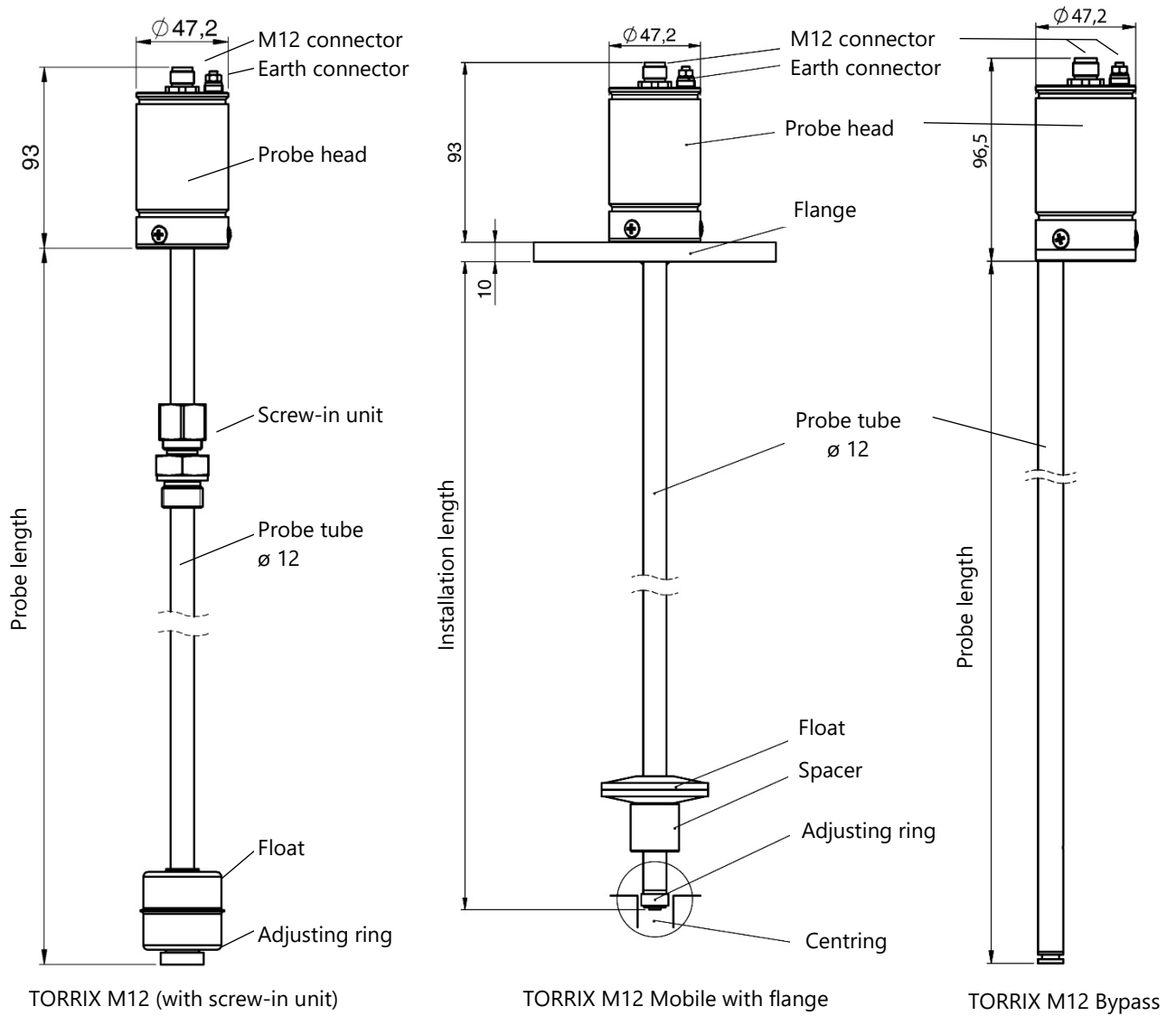

Figure 2: TORRIX M12 versions



The TORRIX Bypass type is supplied without process connection or float.

4 Mounting

This section describes how to install the level sensor depending on the type of the device (see the following figures).



For the installation and maintenance of the sensors, all national Regulations as well as the generally accepted rules of engineering and this manual must be observed.



This also applies to any local safety and accident prevention regulations which are not stated in this manual.



During installation, take great care not to bend the probe tube, and protect the float from shock and impact loads.



Installing a level sensor in areas exposed to a powerful external magnetic field is not permitted because this could impair gauging.



The level sensor can also be fitted into containers from underneath. When mounted without centring or guiding aid, the maximum length of the level sensor is 2 m.



If the float is removed during assembly, it must be pushed back onto the probe tube with the "TOP" marking oriented towards the probe head so that a correct measurement can be made.

4.1 Mounting with screw-in unit

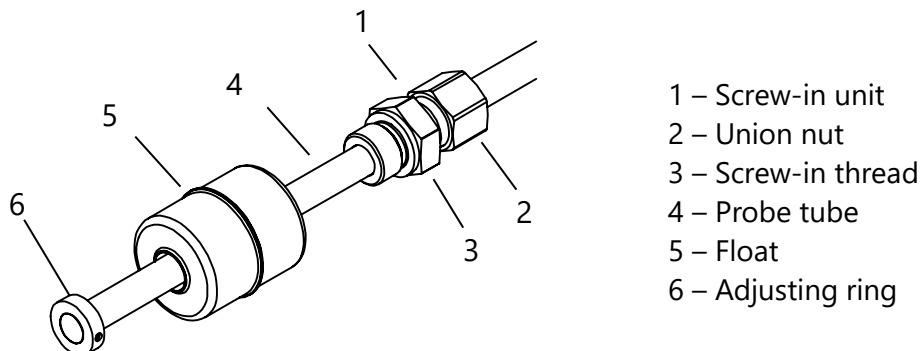

Figure 3: Mounting with screw-in unit



Dismantling the floats is only necessary if the floats do not fit through the mounting hole in the tank. Otherwise, follow steps 4, 7 and, if necessary, 8.

Insert the level sensor into the tank (see Figure 3):

- (1) Loosen the threaded pins from the adjusting ring (6) and remove the adjusting ring
- (2) Remove the float (5) from the probe tube (4)
- (3) If necessary, slide the screw-in unit (1) on the probe tube
- (4) Insert the level sensor into the tank, provide the screw-in thread (3) with a suitable sealing material, screw it in and tighten
- (5) Slide the float (5) back onto the probe tube (4)



For correct measurement, the floats must be pushed onto the probe tube with the "TOP" marking oriented towards the probe head.

- (6) Push on the adjusting ring (6), position the threaded pins over the groove and tighten
- (7) Adjust the height of the process connection, grease the union nut (2) with Gliss Lubricant 5GP or a similar grease paste for pre-assembly of stainless steel cutting rings and fix it finger-tight by hand
- (8) Fix the union nut (2) with a wrench by a 1¼ clockwise turn (see following figure)

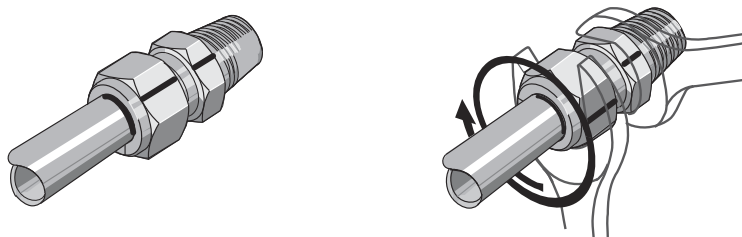

Figure4: Tightening the compression fitting

4.2 Mounting with flange



Because of the risk of bending, the TORRIX Flange must not be held by the probe tube.



The bolts or nuts and the seals are the responsibility of the operating company and must be selected depending on the fluid.

The probe tube is firmly welded to the flange, so the installation length cannot be changed.

- (1) Fasten flange and seal with the flange bolts and nuts.
- (2) If the float does not fit through the installation opening, see chapter Mounting with screw-in unit““.

4.3 Mounting with Bypass

The level sensor is mounted at the side of the bypass tube using suitable non-magnetic fasteners.



To ensure reliable gauging, the probe tube must be fitted with no deformation on the outside.



The distance between the probe and bypass tubes must be as small as possible.



Only floats approved by FAFNIR can be used.

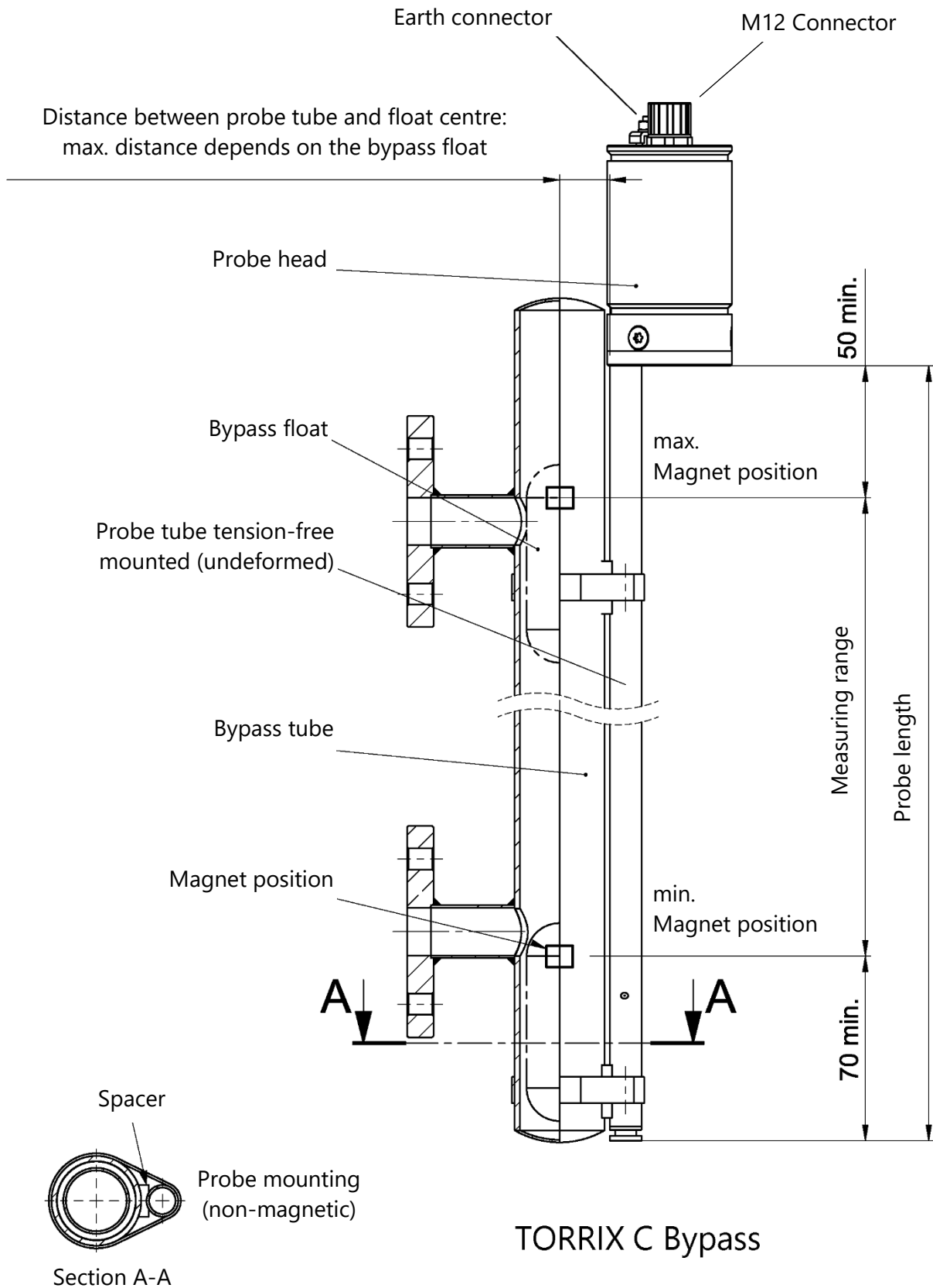

Figure 5: Installation on the bypass

5 Electrical connection

The electrical connection is made at the probe head via the M12 plug connection.

The earth connector on the probe head can be used for earthing the probe or for equipotential bonding.



The earthing or equipotential bonding must be carried out by the installer in accordance with the respective national installation regulations.



Protect the probe head against the ingress of water. A secure sealing must be guaranteed. Make sure that the cable glands and the probe head cover are screwed tight.



For TORRIX Ex... versions, the technical data of the EU-Type Examination Certificate and the instructions must be observed (see appendix).



In the intrinsically safe version, the TORRIX Ex level sensor may be connected in potentially explosive atmospheres only to associated equipment that have been certified by a recognised inspection authority.



If the level sensor is used in a potentially explosive atmospheres, the permissible external capacitance (C_o) and inductance (L_o) of the associated equipment must not be exceeded, see electrical data of the equipment.



The connecting cable to the associated apparatus must be marked if used in potentially explosive atmosphere, preferably as blue cable for intrinsically safe electric circuits.

5.1 Connection Diagrams

5.1.1 Wiring diagram TORRIX C

The level sensor without Ex approval is installed in accordance with the following wiring diagram:

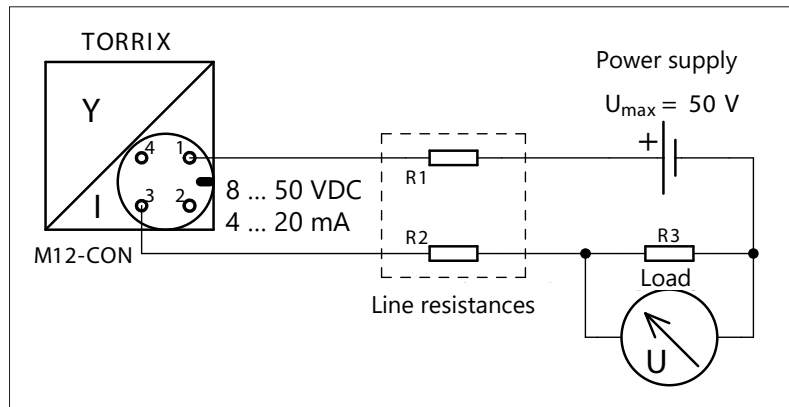

Figure 6: Wiring diagram TORRIX C

Power supply: $U_{\max} = 50 \text{ VDC}$

Minimum supply voltage: $U_{\min} = 8 \text{ V}$

Maximum power consumption: $I_{\max} = 21.5 \text{ mA}$

5.1.2 Wiring diagram TORRIX Ex C

The level sensor with Ex approval is installed in potentially explosive atmosphere according to the following wiring diagram:

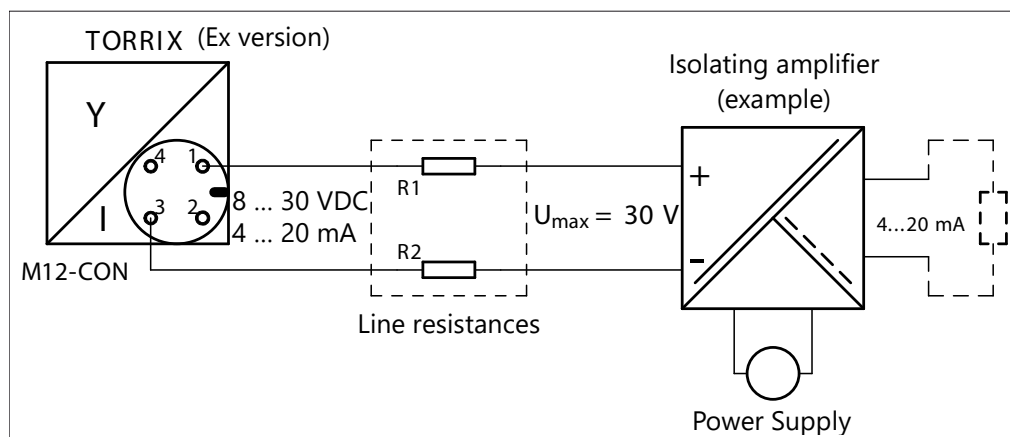

Figure 7: Wiring diagram TORRIX Ex C

Power supply: $U_{\max} = 30 \text{ VDC}$

Minimum supply voltage: $U_{\min} = 8 \text{ V}$

Maximum power consumption: $I_{\max} = 21.5 \text{ mA}$

5.1.3 Wiring diagram TORRIX RS485

The level sensor without Ex approval is installed in accordance with the following wiring diagram:

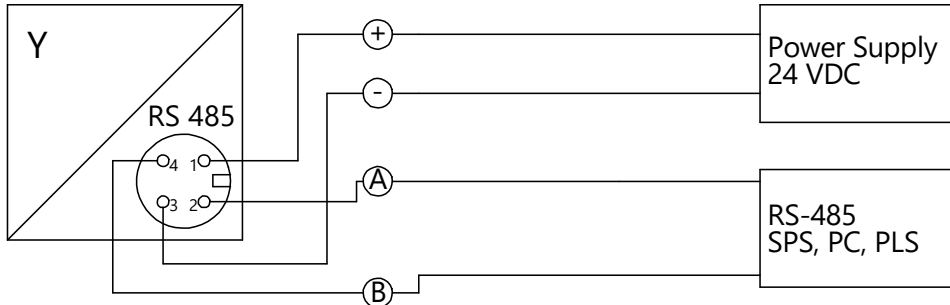

Figure 8: Wiring diagram TORRIX RS485

Power supply: $U_{max} = 50 \text{ VDC}$

Minimum supply voltage: $U_{min} = 8 \text{ V}$

5.1.4 Wiring diagram TORRIX Ex RS485

The level sensor with Ex approval is installed in potentially explosive atmosphere according to the following wiring diagram:

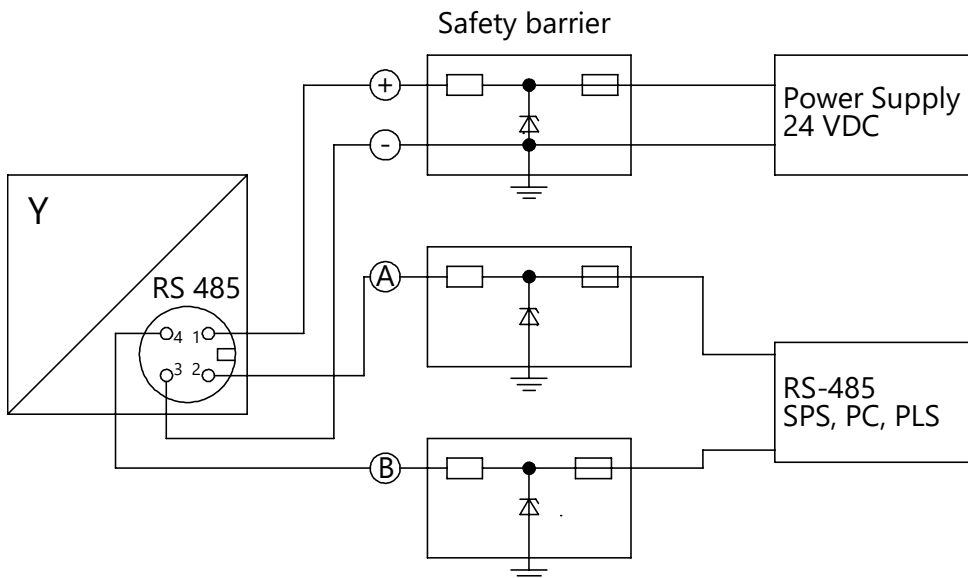

Figure 9: Wiring diagram TORRIX Ex RS485

Power supply: $U_{max} = 30 \text{ VDC}$

Minimum supply voltage: $U_{min} = 8 \text{ V}$

5.1.5 Wiring diagram TORRIX (Ex) SC

TORRIX Ex SC communicates via the FAFNIR protocol with a FAFNIR evaluation unit. It can therefore operate only in combination with VISY-Command or VPI.

For connection instructions of TORRIX (Ex) SC to the evaluation unit, see:



Technical documentation VISY-Command, art. no. 207184



Technical documentation VPI, art. no. 350068

5.2 Connection cable

The connection cable between the TORRIX (Ex) C and the associated equipment must have the following properties:

- 2-wire unshielded cable
- The connecting cable to the associated apparatus must be marked if used in potentially explosive atmosphere, preferably as blue cable for intrinsically safe electric circuits.

The connection cable between TORRIX (Ex) SC and VISY-Command or VPI must have the following properties:

- 4-wire unshielded cable
- Cable cross-section (4 x 0.5 mm² up to 100m or 4 x 1.0 mm² up to 200 m)
- Maximum diameter 6 to 10 mm for reliable sealing by the cable gland in VISY-Command.
- The connecting cable to the associated apparatus must be marked if used in potentially explosive atmosphere, preferably as blue cable for intrinsically safe electric circuits.

The connection cable between the TORRIX (Ex) RS485 and the evaluation system must have the following properties:

- 4-wire unshielded cable
- Cable cross-section (4 x 0.5 mm² up to 100m or 4 x 1.0 mm² up to 200 m)
- The connecting cable to the associated apparatus must be marked if used in potentially explosive atmosphere, preferably as blue cable for intrinsically safe electric circuits.

5.3 Length of the connection cable (TORRIX 4 ... 20 mA variants)



The cable (length and cross-section) must be chosen so that the supply voltage will not fall below the sensor-specific minimum voltage (U_{min}) for the level sensor in the case of the highest current consumption (I_{max}).

The maximum resistance (supply voltage \div maximum current consumption) summarized from cable resistance and possible load must not be exceeded. The maximum cable length is calculated as follows:

L = cable length [m]

U = supply voltage [VDC] minus tolerance value (e.g. $\pm 5\%$)

U_{min} = minimum supply voltage at the level sensor [VDC]

I_{max} = maximum power consumption [A]

R_B = maximum load resistance

R_A = cable resistance per m copper cable [Ω/m] at cable cross-section A [mm^2]

Cable length L

$$L = (((U - U_{min}) / I_{max}) - R_B) / R_A$$

The following table shows the cable resistance R_A per m copper cable of different cross-sections:

Cable cross-section A [mm^2]	Cable resistance R_A per m copper cable [Ω/m]
0.5	0.0356
1.0	0.0178

Example calculation for determining the cable length:

Supply voltage U = 12 VDC – 5 % = 11.4 VDC

Minimum supply voltage at the level sensor U_{min} = 8 VDC

Maximum power consumption I_{max} = 21.5 mA

Maximum load R_B = 86.8 Ω

Cable resistance R_A = 0.0356 Ω/m at cable cross-section A = 0.5 mm^2

$$L = (((11.4 - 8) / 0.0215) - 86.8) / 0.0356 = 2000 \text{ m}$$

A copper cable (2-core) can theoretically be up to 1000 m long with the parameters of this example.

5.4 Wiring



The level sensors may only be wired with the power disconnected.

For the wiring, continue as follows:

- a) If not already connected, plug the M12 female connector of the FAFNIR connection cable onto the M12 male connector of the probe head.

First tighten the union nut of the M12 female connector by hand and then fix the nut with an open-ended spanner by a 180° turn.

The tightening torque should be between 100 ... 150 Ncm.

- b) **Assignment of the connection cable for TORRIX (Ex) C:**

Connect the cable coming from the evaluation unit with the FAFNIR connection cable, for example using an installation sleeve, in the following pin assignment



Pin 2 and 4 are internally used and must not be connected!

Signal		Colour coding of the FAFNIR cable	Pin assignment of the M12 female connector
Voltage	+	brown	Pin 1
used internally		white	Pin 2
Voltage	-	blue	Pin 3
used internally		black	Pin 4

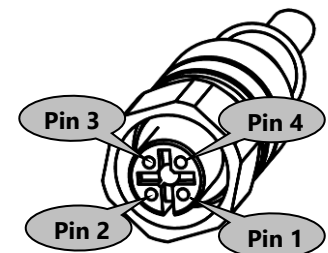

Connection cable TORRIX (Ex) C

- c) **Assignment of connection cable for TORRIX (Ex) SC and TORRIX (Ex) RS485:**

Connect the cable coming from the evaluation unit with the FAFNIR connection cable, for example using an installation sleeve, in the following pin assignment:

Signal		Colour coding of the FAFNIR cable	Pin assignment of the M12 female connector
Voltage	+	brown	Pin 1
Communication	A	white	Pin 2
Voltage	-	blue	Pin 3
Communication	B	black	Pin 4

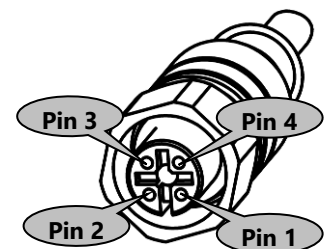

Connection cable for TORRIX (Ex) SC and TORRIX (Ex) RS485

6 Adjustment

6.1 TORRIX (Ex) C configuration

The configuration is done with the computer using the TORRIX configuration tool, see technical documentation:



Technical documentation TORRIX Configuration Tool, art. no. 350258



The configuration with the computer must not be carried out within the potentially explosive area.

6.1.1 Failure mode

If a malfunction is preventing the level sensor from recording a plausible float position, i.e. the measured level is incorrect, the sensor will enter the failure mode after a short time. Failure mode signalling conforms to the NAMUR NE43 recommendation. The failure current is set by default to 21.5 mA but this value can also be set to 3.6 mA.

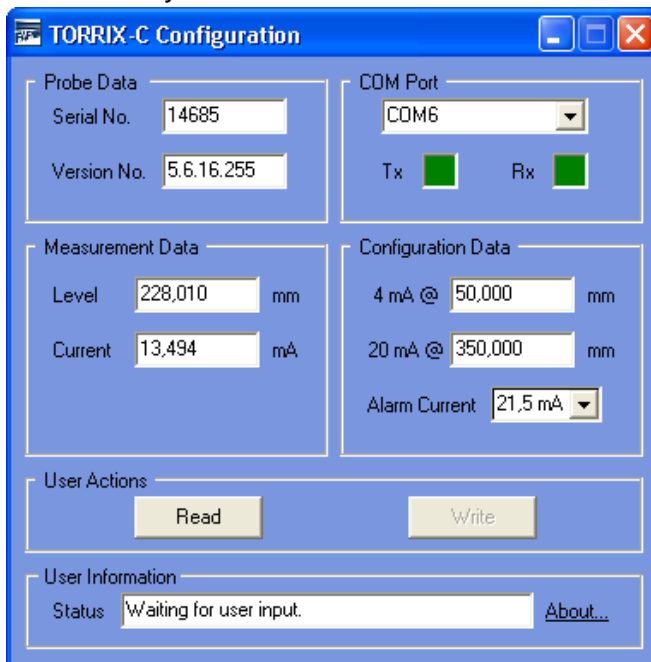

The adjustment of the current consumption in failure mode is done via the configuration tool (see left figure) with the selection box "Alarm Current".

Figure 10: TORRIX Configuration Tool



The adjustment of the current consumption during the failure mode is not saved until the "Write" button has been pressed. The new configuration is retained even if the level sensor is subsequently disconnected from the power supply.

6.2 TORRIX (Ex) SC configuration

The configuration is done via VISY-Command, or in the case of VPI via the host system.

6.2.1 Failure mode

Error messages are output via the protocol.

6.3 TORRIX (Ex) RS485 configuration

The configuration is done with the computer using the TORRIX configuration tool, see technical documentation:



TORRIX Configuration Tool, art. no. 350258



The configuration with the computer must not be carried out within the potentially explosive area.

7 Maintenance

7.1 Servicing

The filling level sensor is maintenance-free.

7.2 Return Shipment

Before returning any FAFNIR equipment, the Return Material Authorization (RMA) from FAFNIR customer service is required. Please contact your account manager or the customer service to receive the instructions on how to return goods.



The return of FAFNIR products is only possible after approval by the FAFNIR customer service.

8 Technical Data



Further technical data you also find in the EU-Type Examination Certificate and in the instructions, see the appendix of this manual.

8.1 Sensor

Electrical connection TORRIX (Ex) C	2-wire connection 3.8 ... 20.5 mA current consumption for measured value output 3.6 mA or 21.5 mA current consumption in the event of a fault
TORRIX (Ex) SC	4-wire connection (TTL signals + power supply)
TORRIX (Ex) RS485	4-wire connection (RS485 signals + power supply)
Supply voltage TORRIX C / RS485	8 ... 50 VDC
TORRIX Ex C / RS485	8 ... 30 VDC
Index of protection	IP68 (test conditions IPX8: immersion depth of 2 m for 30 days)
Process connection	Screw-in unit for stepless height adjustment Standard G ½ (compression fitting) Flange (on request) Material see probe tube
Probe head	Height 93 mm Diameter 47.2 mm Material stainless steel (1.4305 / 303) M12 connector Temperature -40 ... +85 °C
Probe tube	Probe lengths from 100 mm to 6 m, as Flex version up to 22 m Diameter 12 mm (other diameters on request) Material stainless steel 1.4571 (316Ti) or 1.4301 (304) (Hastelloy, or other materials on request) Standard temperature -40 °C ... +85 °C Normal temperature (NT) -40 °C ... +125 °C High temperature (HT) -40 °C ... +250 °C Maximum temperature (HHT) -40 °C ... +450 °C Low temperature (LT) -65 °C ... +125 °C Minimum temperature (LLT) -200 °C ... +85 °C
Communication	TORRIX (Ex) C 4 ... 20 mA TORRIX (Ex) SC FAFNIR protocol TORRIX (Ex) RS485 Modbus ASCII / FDA / FAFNIR UDP Protocol

Measuring accuracy Digital component HT/HHT	Linearity better than ± 1 mm or ± 0.05 %, better than ± 0.01 % per K Repetition accuracy better than 0.1 mm Resolution better than 50 μ m
Measuring accuracy Digital component NT/LT (on request)	Linearity better than ± 0.2 mm or ± 0.01 %, better than ± 0.001 % per K Repetition accuracy better than 0.05 mm Resolution better than 10 μ m
Measuring accuracy Analogue component	Linearity better than ± 0.01 % Temperature coefficient better than 0.01% per K Resolution better than 0.5 μ A (16 bit)

8.2 Floats

The float is an essential component of the level sensor that must be matched to the medium in respect of density, pressure resistance and material durability.

The following floats are exchangeable and can be ordered separately. Other float types and materials are available on request.

 *The density and magnet position of floats of the same type may vary slightly, so that a readjustment may be necessary.*

 *All floats can also be used at a pressure of -1 bar (vacuum).*

Excerpt from the product range of floats:

Min. density of medium [g/cm ³]	Material	Max. operating pressure [bar] at 20 °C *)	Shape [mm]
0.5	Titanium	20	Ball \varnothing 50
0.6	1.4571 (316Ti)	20	Ball \varnothing 52
0.7	1.4571 (316Ti)	16	Cylinder \varnothing 53
0.7	C276	10	Cylinder \varnothing 46
0.7	1.4571 (316Ti)	40	Ball \varnothing 52
0.85	1.4571 (316Ti)	20	Ball \varnothing 43
0.95	1.4571 (316Ti)	50	Ball \varnothing 43

*) above 50 °C the maximum operating pressure decreases



Pressure resistance is guaranteed for undamaged floats only. Even the most minor and invisible dents, which can occur if, for example, the float is dropped from a bench onto a stone floor, are sufficient to cause a significant deterioration in pressure resistance.

9 List of Figures

Figure 1: How the magnetostrictive measuring principle works.....	3
Figure 2: TORRIX M12 versions.....	4
Figure 3: Mounting with screw-in unit.....	6
Figure 4: Tightening the compression fitting.....	6
Figure 5: Installation on the bypass.....	8
Figure 6: Wiring diagram TORRIX C.....	10
Figure 7: Wiring diagram TORRIX Ex C.....	10
Figure 8: Wiring diagram TORRIX RS485.....	11
Figure 9: Wiring diagram TORRIX Ex RS485.....	11
Figure 10: TORRIX Configuration Tool.....	15



**EU-Konformitätserklärung
EU Declaration of Conformity
Déclaration UE de Conformité
Dichiarazione di Conformità UE**



FAFNIR GmbH, Deutschland / Germany / Allemagne / Germania

erklärt als Hersteller in alleiniger Verantwortung, dass die Produkte
declares as manufacturer under sole responsibility that the products
déclare sous sa seule responsabilité en qualité de fabricant que les produits
dichiara sotto la sola responsabilità del produttore, che i prodotti sono

**Füllstandsensoren / Filling Level Sensors / Capteurs de Niveau / Sensori di livello
TORRIX ... / VISY-Stick ...**

den Vorschriften der europäischen Richtlinien
comply with the regulations of the European directives
sont conformes aux réglementations des directives européennes suivantes
rispetta i regolamenti delle direttive europee

2011/65/EU	Beschränkung der Verwendung bestimmter gefährlicher Stoffe in Elektro- und Elektronikgeräten	RoHS
2011/65/EU	Restriction of the use of certain hazardous substances in electrical and electronic equipment	RoHS
2011/65/UE	Limitation de l'utilisation de certaines substances dangereuses dans les équipements électriques et électroniques	RoHS
2011/65/UE	Restrizione dell'uso di determinate sostanze pericolose nelle apparecchiature elettriche ed elettroniche	RoHS
2014/30/EU	Elektromagnetische Verträglichkeit	EMV
2014/30/EU	Electromagnetic compatibility	EMC
2014/30/UE	Compatibilité électromagnétique	CEM
2014/30/UE	Compatibilità elettromagnetica	CEM
2014/34/EU	Geräte und Schutzsysteme zur bestimmungsgemäßen Verwendung in explosionsgefährdeten Bereichen	ATEX
2014/34/EU	Equipment and protective systems intended for use in potentially explosive atmospheres	ATEX
2014/34/UE	Appareils et systèmes de protection destinés à être utilisés en atmosphères explosibles	ATEX
2014/34/UE	Apparecchi e sistemi di protezione destinati a essere utilizzati in atmosfera potenzialmente esplosiva	ATEX

durch die Anwendung folgender harmonisierter Normen entsprechen
by applying the harmonised standards
par l'application des normes
applicando le norme armonizzate

RoHS / RoHS / RoHS / RoHS	EN IEC 63000:2018		
EMV / EMC / CEM / CEM	EN 61326-1:2013		
ATEX / ATEX / ATEX / ATEX	EN IEC 60079-0:2018	EN 60079-1:2014	EN 60079-11:2012
	EN 60079-26:2015	EN 60079-31:2014	

Die Produkte sind bestimmt als Elektro- und Elektronikgeräte der RoHS-
The products are determined as electrical and electronic equipment of RoHS
Les produits sont déterminés comme des équipements électriques et électroniques de RoHS
I prodotti sono determinati come apparecchiature elettriche ed elettroniche della RoHS

Kategorie / Category / Catégorie / Categoria **Überwachungs- und Kontrollinstrumenten in der Industrie /
Industrial Monitoring and Control Instruments /
Instruments de contrôle et de surveillance industriels /
Strumenti di monitoraggio e controllo industriali**

Die Produkte entsprechen den EMV-Anforderungen
The products comply with the EMC requirements
Les produits sont conformes aux exigences CEM
I prodotti sono conformi ai requisiti CEM

Störaussendung / Emission / Émission / L'emissione **Klasse B / Class B / Classe B / Classe B**
Störfestigkeit / Immunity / D'immunità / Immunità **Industrielle elektromagnetische Umgebung /
Industrial electromagnetic environment /
Environnement électromagnétique industriel /
Ambiente elettromagnetico industriale**

Die notifizierte Stelle TÜV NORD CERT GmbH, 0044 hat eine EU-Baumusterprüfung durchgeführt und folgende Bescheinigung ausgestellt
The notified body TÜV NORD CERT GmbH, 0044 performed a EU-type examination and issued the certificate
L'organisme notifié TÜV NORD CERT GmbH, 0044 a effectué examen UE de type et a établi l'attestation
L'organismo notificato TÜV NORD CERT GmbH, 0044 ha effettuato esame UE del tipo e rilasciato il certificato

TORRIX Ex ... / VISY-Stick ...

TÜV 99 ATEX 1496 X

Hamburg, 2023-04-14

Ort, Datum / Place, Date / Lieu, Date / Luogo, data

Geschäftsführer / Managing Director / Gérant / Direttore Generale: René Albrecht



Translation

(1) **EU-Type Examination Certificate**

(2) Equipment and protective systems intended for use in potentially explosive atmospheres, **Directive 2014/34/EU**

(3) **Certificate Number** TÜV 99 ATEX 1496 X **Issue:** 03
(4) for the product: Filling level sensors type VISY-Stick ... and type TORRIX Ex...
(5) of the manufacturer: **FAFNIR GmbH**
(6) Address: Schnackenburgallee 149 c
22525 Hamburg
Germany

Order number: 8003035365
Date of issue: See date of signature

(7) The design of this product and any acceptable variation thereto are specified in the schedule to this EU-Type Examination Certificate and the documents therein referred to.

(8) The TÜV NORD CERT GmbH, Notified Body No. 0044, in accordance with Article 17 of the Directive 2014/34/EU of the European Parliament and the Council of 26 February 2014, certifies that this product has been found to comply with the Essential Health and Safety Requirements relating to the design and construction of products intended for use in potentially explosive atmospheres given in Annex II to the Directive. The examination and test results are recorded in the confidential ATEX Assessment Report No. 22 203 302211.

(9) Compliance with the Essential Health and Safety Requirements has been assured by compliance with:
EN IEC 60079-0:2018/AC:2020-02 **EN 60079-1:2014/AC:2018-09** **EN 60079-11:2012**
EN 60079-26:2015 **EN 60079-31:2014**

except in respect of those requirements listed at item 18 of the schedule.

(10) If the sign "X" is placed after the certificate number, it indicates that the product is subject to the Specific Conditions for Use specified in the schedule to this certificate.

(11) This EU-Type Examination Certificate relates only to the design, and construction of the specified product. Further requirements of the Directive apply to the manufacturing process and supply of this equipment. These are not covered by this certificate.

(12) The marking of the product shall include the following:

 **See „Type code and Marking“**

TÜV NORD CERT GmbH, Am TÜV 1, 45307 Essen, notified by the central office of the countries for safety engineering (ZLS), Ident. Nr. 0044, legal successor of the TÜV NORD CERT GmbH & Co. KG Ident. Nr. 0032

The deputy of the head of the notified body

 Digital
unterschrieben von
Meyer Andreas
Datum: 2023.04.04
19:55:26 +02'00'

Hanover office, Am TÜV 1, 30519 Hannover, Tel. +49 511 998-61455, Fax +49 511 998-61590

This certificate may only be reproduced without any change, schedule included.
Excerpts or changes shall be allowed by the TÜV NORD CERT GmbH

(13) **SCHEDULE**

(14) **EU-Type Examination Certificate No. TÜV 99 ATEX 1496 X**

Issue 03

(15) **Description of product:**

The filling level sensors type VISY-Stick ... and type TORRIX Ex... are used for continuous measurement of liquid levels within potentially explosive areas. Floaters are used to detect the fluid levels. These slide on a sensor tube. For interface or water detection, a second float can be mounted on the sensor tube. In addition, the density of the liquid can be determined by means of a density module.

The temperature measuring chain VISY-Stick ... Temp ... is used to measure temperatures at different heights and does not use any floats.

Type code and Marking:

Type VISY-Stick ... (Ex-relevant designations only):

VISY-Stick Sump ...	Environmental sensor (Leakage control)
VISY-Stick Advanced ...	Advanced precision of measurement and temperature sensors
VISY-Stick Flex ...	Flexible sensor tube
VISY-Stick ...	Serial communication
VISY-Stick ... RS485	RS-485 interface
VISY-Stick ... Temp ...	Temperature measuring chain
VISY-Stick ... TLS	TLS interface

Type TORRIX Ex... (Ex-relevant designations only):

TORRIX Ex...	4...20 mA interface (with configuration buttons) optionally with HART protocol
TORRIX Ex C...	4...20 mA interface (without configuration buttons) optionally with HART protocol
TORRIX Ex RS485...	RS-485 interface
TORRIX Ex SC...	Serial communication
TORRIX Ex TAG...	TAG interface (communication in accordance with EN 14116)
TORRIX Ex XT...	RS-485- or 4...20 mA interface optionally with display (Ex i)
TORRIX Exd XT...	RS-485- or 4...20 mA interface optionally with display (Ex d+t+i)
TORRIX Ex...-A	Advanced precision of measurement and temperature sensors
TORRIX Ex... Flex	Flexible sensor tube
TORRIX Ex... PL	With plastic coating against very aggressive media

Schedule to EU-Type Examination Certificate No. TÜV 99 ATEX 1496 X

Issue 03

<ul style="list-style-type: none"> • VISY-Stick ... • VISY-Stick (Flex) Temp • VISY-Stick ... RS485 • VISY-Stick (Flex) Temp RS485 • TORRIX Ex... • TORRIX Ex C... • TORRIX Ex RS485... • TORRIX Ex SC... • TORRIX Ex TAG... • TORRIX Ex XT... 	<ul style="list-style-type: none"> II 1 G Ex ia IIC T6...T1 Ga II 1/2 G Ex ia IIC T6...T1 Ga/Gb II 2 G Ex ia IIC T6...T1 Gb II 2 D Ex ia IIIC TX°C Db (see thermal data)
<ul style="list-style-type: none"> • VISY-Stick Advanced ... • VISY-Stick ... Flex ... • VISY-Stick ... Advanced RS485 • VISY-Stick ... Flex RS485 • TORRIX Ex ...-A • TORRIX Ex ... Flex • TORRIX Ex ... PL • TORRIX Ex C...-A • TORRIX Ex C... Flex • TORRIX Ex C... PL • TORRIX Ex RS485...-A • TORRIX Ex RS485... Flex • TORRIX Ex RS485... PL • TORRIX Ex SC...-A • TORRIX Ex SC... Flex • TORRIX Ex SC... PL • TORRIX Ex TAG...-A • TORRIX Ex TAG... Flex • TORRIX Ex TAG... PL • TORRIX Ex XT...-A • TORRIX Ex XT... Flex • TORRIX Ex XT... PL 	<ul style="list-style-type: none"> II 1 G Ex ia IIB T6...T1 Ga II 1/2 G Ex ia IIB T6...T1 Ga/Gb II 2 G Ex ia IIB T6...T1 Gb II 2 D Ex ia IIIC TX°C Db (see thermal data)
<ul style="list-style-type: none"> • VISY-Stick ... TLS • VISY-Stick (Flex) Temp TLS 	<ul style="list-style-type: none"> II 1 G Ex ia IIC T4...T1 Ga II 1/2 G Ex ia IIC T4...T1 Ga/Gb II 2 G Ex ia IIC T4...T1 Gb II 2 D Ex ia IIIC TX°C Db (see thermal data)
<ul style="list-style-type: none"> • VISY-Stick ... Advanced TLS • VISY-Stick ... Flex TLS 	<ul style="list-style-type: none"> II 1 G Ex ia IIB T4...T1 Ga II 1/2 G Ex ia IIB T4...T1 Ga/Gb II 2 G Ex ia IIB T4...T1 Gb II 2 D Ex ia IIIC TX°C Db (see thermal data)
<ul style="list-style-type: none"> • TORRIX Exd XT... 	<ul style="list-style-type: none"> II 1/2 G Ex ia/db IIC T6...T1 Ga/Gb II 2 G Ex db ia IIC T6...T1 Gb II 2 D Ex ia tb IIIC TX°C Db (see thermal data)
<ul style="list-style-type: none"> • TORRIX Exd ...-A • TORRIX Exd ... Flex • TORRIX Exd ... PL 	<ul style="list-style-type: none"> II 1/2 G Ex ia/db IIB T6...T1 Ga/Gb II 2 G Ex db ia IIB T6...T1 Gb II 2 D Ex ia tb IIIC TX°C Db (see thermal data)

This certificate may only be reproduced without any change, schedule included.
Excerpts or changes shall be allowed by the TÜV NORD CERT GmbH

Electrical data:

VISY-Stick ...; VISY-Stick (Flex) Temp; TORRIX Ex SC...; VISY-Stick Advanced ...;
VISY-Stick ... Flex ...; TORRIX Ex SC...-A; TORRIX Ex SC... Flex and TORRIX Ex SC... PL:

Signal and power supply
 (Terminals +, -, A, B) or (M12-Plug)

In type of protection intrinsic safety Ex ia IIC/IIB/IIIC
 Only for connection to certified intrinsically safe circuits.
 Maximum values:
 $U_i = 15 \text{ V}$
 $I_i = 60 \text{ mA}$
 $P_i = 100 \text{ mW}$
 Effective internal capacitance $C_i = 10 \text{ nF}$
 Effective internal inductance $L_i = 100 \text{ }\mu\text{H}$

VISY-Stick ... RS485; VISY-Stick (Flex) Temp RS485; TORRIX Ex...; TORRIX Ex C...;
TORRIX Ex RS485...; TORRIX Ex TAG...; TORRIX Ex XT...; VISY-Stick ... Advanced RS485;
VISY-Stick ... Flex RS485; TORRIX Ex ...-A; TORRIX Ex ... Flex; TORRIX Ex ... PL;
TORRIX Ex C...-A; TORRIX Ex C... Flex; TORRIX Ex C... PL; TORRIX Ex RS485...-A;
TORRIX Ex RS485... Flex; TORRIX Ex RS485... PL; TORRIX Ex TAG...-A;
TORRIX Ex TAG... Flex; TORRIX Ex TAG... PL; TORRIX Ex XT...-A; TORRIX Ex XT... Flex
and TORRIX Ex XT... PL:

Signal and power supply
 (Terminals +, -, A, B resp. +, -) or
 (M12-Plug)

In type of protection intrinsic safety Ex ia IIC/IIB/IIIC
 Only for connection to certified intrinsically safe circuits.
 Maximum values:
 $U_i = 30 \text{ V}$
 $I_i = 200 \text{ mA at } T_a \leq +70 \text{ }^\circ\text{C}$
 $I_i = 100 \text{ mA at } T_a \leq +85 \text{ }^\circ\text{C}$
 $P_i = 1 \text{ W}$
 Effective internal capacitance $C_i = 10 \text{ nF}$
 Effective internal inductance $L_i = 20 \text{ }\mu\text{H}$

VISY-Stick ... TLS; VISY-Stick (Flex) Temp TLS; VISY-Stick ... Advanced TLS and
VISY-Stick ... Flex TLS:

Signal and power supply
 (Terminals +, -) or (M12-Plug)

In type of protection intrinsic safety Ex ia IIC/IIB/IIIC
 Only for connection to certified intrinsically safe circuits.
 Maximum values:
 $U_i = 13 \text{ V}$
 $I_i = 200 \text{ mA}$
 $P_i = 625 \text{ mW}$
 Effective internal capacitance $C_i = 20 \text{ nF}$
 Effective internal inductance $L_i = 410 \text{ }\mu\text{H}$

Schedule to EU-Type Examination Certificate No. TÜV 99 ATEX 1496 X

Issue 03

TORRIX Exd XT...; TORRIX Exd ...-A; TORRIX Exd ... Flex and TORRIX Exd ... PL:

Signal and power supply
(Terminals +, -, A, B) For connection to non-intrinsically safe circuits with the following values:

$$U = 12 V_{d.c.} \dots 50 V_{d.c.}; I = 4 \text{ mA} \dots 20 \text{ mA}$$

$$U_m = 253 \text{ V}$$

Heating circuit
(Terminals -, +) For connection to non-intrinsically safe circuits with the following values:

$$U = 24 V_{d.c.} \pm 10 \%$$

$$I = 160 \text{ mA}$$

Thermal data:

VISY-Stick ...; VISY-Stick (Flex) Temp; TORRIX Ex SC...; VISY-Stick Advanced ...;

VISY-Stick ... Flex ...; TORRIX Ex SC...-A; TORRIX Ex SC... Flex and TORRIX Ex SC... PL:

For EPL Ga or EPL Ga/Gb or EPL Gb, the permissible temperature range depending on the variant and the temperature class can be taken from the following table:

Temperature class	Ambient temperature range	Medium temperature range
T6	-40 °C ... +50 °C	-40 °C ... +75 °C
T5	-40 °C ... +65 °C	-40 °C ... +90 °C
T4	-40 °C ... +85 °C	-40 °C ... +125 °C
T3	-40 °C ... +85 °C	-40 °C ... +190 °C
T2	-40 °C ... +85 °C	-40 °C ... +285 °C
T1	-40 °C ... +85 °C	-40 °C ... +435 °C

For EPL Db applications, the permissible ambient temperature range depending on the permissible surface temperature can be taken from the following table:

Maximum surface temperature		Ambient temperature range T_a
Dust layer $\leq 5 \text{ mm}$ $T_5 X^\circ\text{C}$	With total immersion $T X^\circ\text{C}$	
$X^\circ\text{C} = T_a + 30^\circ\text{C}$	$X^\circ\text{C} = 135^\circ\text{C}$	-40 °C ... +85 °C

The equipment is suitable for dusts with an ignition temperature of more than 190 °C under a dust layer of 5 mm (glow temperature).

VISY-Stick ... RS485; VISY-Stick (Flex) Temp RS485; TORRIX Ex ...; TORRIX Ex C...; TORRIX Ex RS485...; TORRIX Ex TAG...; TORRIX Ex XT...; VISY-Stick ... Advanced RS485; VISY-Stick ... Flex RS485; TORRIX Ex ...-A; TORRIX Ex ... Flex; TORRIX Ex ... PL; TORRIX Ex C...-A; TORRIX Ex C... Flex; TORRIX Ex C... PL; TORRIX Ex RS485...-A; TORRIX Ex RS485... Flex; TORRIX Ex RS485... PL; TORRIX Ex TAG...-A; TORRIX Ex TAG... Flex; TORRIX Ex TAG... PL; TORRIX Ex XT...-A; TORRIX Ex XT... Flex and TORRIX Ex XT... PL;

For EPL Ga or EPL Ga/Gb or EPL Gb, the permissible temperature range depending on the variant and the temperature class can be taken from the following table:

Temperature class	Ambient temperature range	Medium temperature range
T6	$I_i \leq 100 \text{ mA}$: -40 °C ... +40 °C $I_i \leq 200 \text{ mA}$: -40 °C ... +25 °C	-40 °C ... +75 °C
T5	$I_i \leq 100 \text{ mA}$: -40 °C ... +55 °C $I_i \leq 200 \text{ mA}$: -40 °C ... +40 °C	-40 °C ... +90 °C
T4	$I_i \leq 100 \text{ mA}$: -40 °C ... +85 °C $I_i \leq 200 \text{ mA}$: -40 °C ... +70 °C	-40 °C ... +125 °C
T3	$I_i \leq 100 \text{ mA}$: -40 °C ... +85 °C $I_i \leq 200 \text{ mA}$: -40 °C ... +70 °C	-40 °C ... +190 °C
T2	$I_i \leq 100 \text{ mA}$: -40 °C ... +85 °C $I_i \leq 200 \text{ mA}$: -40 °C ... +70 °C	-40 °C ... +285 °C
T1	$I_i \leq 100 \text{ mA}$: -40 °C ... +85 °C $I_i \leq 200 \text{ mA}$: -40 °C ... +70 °C	-40 °C ... +435 °C

For EPL Db applications, the permissible ambient temperature range depending on the permissible surface temperature can be taken from the following table:

Maximum surface temperature		Ambient temperature range T_a
Dust layer $\leq 5 \text{ mm}$ $T_5 X^\circ\text{C}$	With total immersion $T X^\circ\text{C}$	
$I_i \leq 100 \text{ mA}$: $X^\circ\text{C} = T_a + 40^\circ\text{C}$	Observe EN 60079-14	-40 °C ... +85 °C
$I_i \leq 200 \text{ mA}$: $X^\circ\text{C} = T_a + 55^\circ\text{C}$	Observe EN 60079-14	-40 °C ... +70 °C

The equipment is suitable for dusts with an ignition temperature of more than 200 °C under a dust layer of 5 mm (glow temperature).

Schedule to EU-Type Examination Certificate No. TÜV 99 ATEX 1496 X Issue 03

VISY-Stick ... TLS; VISY-Stick (Flex) Temp TLS; VISY-Stick ... Advanced TLS and VISY-Stick ... Flex TLS:

For EPL Ga or EPL Ga/Gb or EPL Gb, the permissible temperature range can be taken from the following tables, depending on the variant and the temperature class:

Temperature class	Ambient temperature range	Medium temperature range
T4	-40 °C ... +75 °C	-40 °C ... +125 °C
T3	-40 °C ... +85 °C	-40 °C ... +190 °C
T2	-40 °C ... +85 °C	-40 °C ... +285 °C
T1	-40 °C ... +85 °C	-40 °C ... +435 °C

For EPL Db applications, the permissible ambient temperature range depending on the permissible surface temperature can be taken from the following table:

Maximum surface temperature		Ambient temperature range T_a
Dust layer ≤ 5 mm $T_5 X^\circ C$	With total immersion $T X^\circ C$	
$X^\circ C = 135^\circ C$	$X^\circ C = 135^\circ C$	-40 °C ... +77 °C
$X^\circ C = T_a + 110^\circ C$	Observe EN 60079-14	-40 °C ... +85 °C

The equipment is suitable for dusts with an ignition temperature of more than 270 °C under a dust layer of 5 mm (glow temperature).

TORRIX Exd XT...; TORRIX Exd ...-A; TORRIX Exd ... Flex and TORRIX Exd ... PL:

For EPL EPL Ga/Gb or EPL Gb, the permissible temperature range can be taken from the following tables, depending on the variant and the temperature class:

Temperature class	Ambient temperature range	Medium temperature range
T6	-55 °C ... +50 °C	-55 °C ... +75 °C
T5	-55 °C ... +65 °C	-55 °C ... +90 °C
T4	-55 °C ... +85 °C	-55 °C ... +125 °C
T3	-55 °C ... +85 °C	-55 °C ... +190 °C
T2	-55 °C ... +85 °C	-55 °C ... +285 °C
T1	-55 °C ... +85 °C	-55 °C ... +435 °C

For EPL Db applications, the permissible ambient temperature range depending on the permissible surface temperature can be taken from the following table:

Maximum surface temperature		Ambient temperature range T_a
Dust layer ≤ 5 mm $T_5 X^\circ C$	With total immersion $T X^\circ C$	
$X^\circ C = T_a + 30^\circ C$	Observe EN 60079-14	-55 °C ... +85 °C

The equipment is suitable for dusts with an ignition temperature of more than 190 °C under a dust layer of 5 mm (glow temperature).

- (16) Drawings and documents are listed in the ATEX Assessment Report No. 22 203 302211

(17) Specific Conditions for Use:

1. The permissible temperature range depending on temperature classes resp. on the maximum surface temperature is to be taken from the operating instructions.
2. A reverse heat flow from the process, e.g. by heat dissipation from components of the system, beyond the permissible ambient temperature of the filling level sensor is not permissible. This can be avoided, for example, by suitable thermal insulation of these components or by mounting the pressure transmitter at a greater distance (cooling distance).
3. The medium tangent materials of the filling level sensor have to be resistant to the media.
4. For the uses in potentially explosive gas atmospheres and when using plastic floats, the filling level sensors have to be installed and used in such a way, that electrostatic charging from operation, maintenance and cleaning is excluded.
For the uses in potentially explosive dust atmospheres and when using plastic floats process-related electrostatic charges, e.g. due to passing media have to be excluded.
5. When using titanium floats or the Sump Environmental Sensor, the ignition hazard caused by impact or friction has to be excluded.
6. For EPL Ga/Gb applications the whole device filling level type VISY-Stick ... resp. type TORRIX Ex has to be mounted in a way that allows an installation that results in a sufficiently tight joint (IP66 or IP67) or a flameproof joint (IEC 60079-1) in the direction of the less endangered area.
7. In case of hazards due to pendulum or swinging, the corresponding parts of the level sensor type VISY-Stick ... resp. type TORRIX Ex... have to be effectively secured against these hazards.
8. The cable glands for the filling level sensors type TORRIX Exd XT...; TORRIX Exd ...-A; TORRIX Exd ... Flex and TORRIX Exd ... PL have to be separately assessed and certified in accordance with EN 60079-0; EN 60079-1 and EN 60079-31. In the end-use application the degree of protection min. IP6X shall be maintained in accordance with EN 60079-0 and in compliance with EN 60529.
9. The flameproof joints at type TORRIX Exd... are not intended to be repaired.

(18) Essential Health and Safety Requirements:

No additional ones.

- End of EU-Type Examination Certificate -

**I Range of application**

The filling level sensors are designed for continuous measurement of liquid levels. Floats are used to measure the liquid levels. These slide on a sensor tube. For interface or water detection, a second float can be mounted on the sensor tube. In addition, the density of the liquid can be determined via a density module. The temperature measuring chain VISY-Stick ... Temp ... is used to measure temperatures at different heights and does not use any floats.

The power supply for the devices VISY-Stick ... and the forwarding of the measured data to a superordinate evaluation system is provided by isolating amplifier VP-... or VPI or, in the case of the sensor VISY-Stick ... TLS, e. g. by the TLS-... console from Veeder-Root. If an RS-485 interface is used, the sensor VISY-Stick ... RS485 can be used.

The filling level sensors TORRIX Ex ... can be produced with different interfaces. These are, for example, interfaces "4 ... 20 mA" (TORRIX Ex ... and TORRIX Ex C...), "RS-485" (TORRIX Ex RS485...) or TAG (TORRIX Ex TAG...). The TORRIX Ex... XT... level sensors can be operated either on a 4 ... 20 mA or RS 485 interface. The filling level sensors TORRIX Ex SC... are connected to the isolating amplifier VP-... or VPI.

II Standards

The device is designed according to the following European standards

EN IEC 60079-0:2018	Equipment – General requirements
EN 60079-1:2014	Equipment protection by flameproof enclosures "d"
EN 60079-11:2012	Equipment protection by intrinsic safety "i"
EN 60079-26:2015	Equipment with Equipment Protection Level (EPL) Ga
EN 60079-31:2014	Equipment dust ignition protection by enclosure "t"

III Instructions for safe ...**III.a ... use**

The approval applies to equipment types VISY-Stick ... and TORRIX Ex...

The devices are designed either as intrinsically safe equipment or as flameproof enclosures resp. protection by enclosures with an intrinsically safe part and are suitable for use in potentially explosive atmospheres. The "advanced" (TORRIX Ex...-A, VISY-Stick Advanced ...) and "flexible" filling level sensors (TORRIX Ex... Flex, VISY-Stick ... Flex ...) as well as types with plastic coating against very aggressive media (TORRIX Ex... PL) can be used for all gases of groups IIA and IIB. The temperature measuring chain VISY-Stick ... Temp ... and all other filling level sensors can be used for all gases of groups IIA, IIB and IIC. In addition, all devices can be used for dust groups IIIA, IIIB and IIIC.

With the level sensor in flameproof enclosure respectively with protection by enclosure (TORRIX Exd ...) there is the possibility of using a heater for the display when used in very low ambient temperatures.

To use a non-conductive plastic floats in potentially explosive areas with gases of group IIC the hazard of static charging must be prevented. Here a few conditions need to be observed:

- The use of the float in strongly flowing, non-conductive liquids is forbidden;
- There must be no agitator/mixer in the tank;
- Frictions on non-conductive components are to be avoided;
- The float must not be cleaned in a dry state.

The materials of the sensors that come into contact with the media must be resistant to these media.



III.b ... assembling and dismantling

The assembly and disassembly must solely be carried out with the power disconnected!

Prior to the installation, it may be necessary that the float/s or the density module is disassembled. During the assembly it must be ensured that the float/s or the module is/are mounted the right way on the sensor tube.

Only with the TORRIX Ex ... with screw terminals the opening of the sensor head is planned. Further disassembly may damage the filling level sensor and void its approval.

With the TORRIX Exd ... a certified cable gland must be installed in the flameproof enclosure according to the manufacturer's instructions. The covers of the connection compartment and of the display can be opened after switching off both circuits (sensor and heating) with a four-minute waiting time, whereby the M4 hexagon socket locking screw must first be loosened (screw into the enclosure). To close the cover, screw it back on completely and then secure it with the M4 screw (screw it out of the enclosure against the cover).

III.c ... installation

All wiring operations must solely be carried out with the power disconnected. Special rules and regulations, including EN 60079-14 and local installation regulations, must be observed.

If a device is supplied with screw-in unit, the thread of the screw-in unit must be fitted with a suitable sealing material, screwed into the existing sleeve and tightened. In case of a riser installation the plastic centring aid is plugged onto the sensor head. Then allow the sensor to slide into the riser tube until it stands firmly on the bottom. If the filling level sensor is supplied without process fitting, the installer is responsible for compliance with the Ex requirements.

General information (see also EN 60079-26, Clause 4.3):

If a device is installed into the boundary wall between zone 0 and zone 1, it is essential to ensure that a minimum protection of IP66 or IP67 is achieved after installation.

Through the process connection, there may be an opening in the boundary wall to the area requiring EPL Ga. There is then the risk of the release of flammable gas and the flame entrance.

A heat return flow from the process, e.g. by heat radiation, beyond the permissible ambient temperature is not permissible. This can be avoided, for example, by suitable thermal insulation or by mounting the sensor head of the sensor at a greater distance (cooling distance).

In case of hazards due to oscillation or swinging, the corresponding parts of the sensor must be effectively secured against these hazards.

Flexible filling level sensor (TORRIX Ex... Flex ..., VISY-Stick ... Flex ...)

This type can be produced with different sensor bases to serve for stabilizing the sensor. A base can be a magnetic base. The magnet is then encapsulated in an electricity conducting plastic and can therefore be used in potentially explosive areas.

If this version is manufactured without a fixture, it may only be used in non-flowing liquids or it must be ensured that it does not turn, e.g. by a protective tube or by a weight as a sensor foot.

LPG filling level sensor VISY-Stick ... LPG ...

The adjustable installation kit for LPG tanks was developed to allow the sensor to be installed and removed at any time without any additional work and without having to open the tank. The adjustable installation kit for LPG tanks consists of a jacket pipe with special LPG float made of BUNA and a ¾" NPT cutting ring fitting. In the case of installation with a cutting ring fitting, the position of the sensor can no longer be altered after the union nut has been tightened.

Environmental sensor VISY-Stick Sump ...

This environmental sensor can be fixed with the mounting kit.

When wiring the intrinsically safe sensor to the associated apparatus (preferably blue coloured cable), the approved inductance and capacitance of the associated apparatus must not be exceeded. The terminals of the sensor must be connected to the same terminals of the isolating amplifier.



For the filling level sensors with connection terminals, the terminal designation are "+" and "-" and additionally "A" and "B" for the type TORRIX Ex... XT... ("+" and "-" are added for the type TORRIX Exd ... for the terminal block "Heater"). For devices with M12 plug, the pin assignments are as follows:

Pin	TORRIX Ex SC ... VISY-Stick ...	TORRIX Ex C ... TORRIX Ex TAG ... VISY-Stick ... TLS	TORRIX Ex RS485 ... VISY-Stick ... RS485	M12 cable (female)
1	+	+	+	
2	A		A (+)	
3	-	-	-	
4	B		B (-)	

Table 1: Pin assignment of the sensors

The sensors must be integrated into the potential equalization of the hazardous area. A PA connecting terminal on the sensor head is available for integration of the devices into the potential equalization.

General information (see also EN 60079-14:2013, clause 6.4.1):

Exposed conductive parts need not be separately connected to the equipotential bonding system if they are firmly secured to and are in conductive contact with structural parts or piping which are connected to the equipotential bonding system.

III.d ... adjustment

For the operation the sensors, no Ex-relevant adjustments are necessary.

III.e ... putting into service

Before putting into service, all devices must be checked for correct connection and installation. The electrical supply, including the connected devices, must be checked. For the level sensors type TORRIX Exd ..., the cable entry and the covers must be checked for correct installation.

III.f ... maintenance (servicing and emergency repair)

The apparatus is generally maintenance-free. In the case of a defect, this must be returned to the manufacturer FAFNIR or one of its representatives.

For equipment that is completely intrinsically safe, there is compliance in the dielectric strength test between the intrinsically safe circuit and the chassis of the equipment with a voltage of 500 V_{AC} in accordance with EN 60079-11, Clause 6.3.13. For level sensors type TORRIX Exd ... there is no compliance.

With the type TORRIX Ex... XTS... the display may be replaced. To do this, the cover of the display must first be removed (see section III.b). By pushing in the flaps of the display, it can be levered out bit by bit. Particularly with the TORRIX Exd ... version, care must be taken during this procedure not to damage the enclosure and especially the thread for the cover. The connections (plugs and sockets) on the back of the indicator must be disconnected. Now the new unit can be connected. The number of poles and the polarity reversal protection of the connectors determine the correct connection. After the electrical connection, the unit is placed in the grooves with the snap-in mechanism (the orientation can be changed later, as the unit can be rotated in the enclosure. By pressing the flaps in again, the display can be lowered into the enclosure until it clicks into place. After aligning the new indicator, refit the cover (see section III.b).

Warning: The type VISY-Stick Sump ... and floats made of non-conductive plastic must only be cleaned with a damp cloth, to minimize the risk of electrostatic charging.

Warning: The TORRIX Exd ... version may only be opened without voltage.



IV Equipment marking

- 1 Manufacturer: FAFNIR GmbH, 22525 Hamburg
- 2 Type designation: TORRIX Ex ... / VISY-Stick ...
- 3 Certificate number: TÜV 99 ATEX 1496 X
- 4 Ex marking:

TORRIX Ex ... / TORRIX Ex C... / TORRIX Ex RS485... / TORRIX Ex SC... / TORRIX Ex TAG... / TORRIX Ex XT... / VISY-Stick ... / VISY-Stick RS485... / VISY-Stick (Flex) Temp / VISY-Stick (Flex) Temp RS485

	II 1 G	Ex ia IIC T6...T1 Ga
	II 1/2 G	Ex ia IIC T6...T1 Ga/Gb
	II 2 G	Ex ia IIC T6...T1 Gb
	II 2 D	Ex ia IIIC TX °C Db

TORRIX Ex ...-A / TORRIX Ex ... Flex / TORRIX Ex ... PL / TORRIX Ex C...-A / TORRIX Ex C... Flex / TORRIX Ex C... PL / TORRIX Ex RS485...-A / TORRIX Ex RS485... Flex / TORRIX Ex RS485... PL / TORRIX Ex SC...-A / TORRIX Ex SC... Flex / TORRIX Ex SC... PL / TORRIX Ex TAG...-A / TORRIX Ex TAG... Flex / TORRIX Ex TAG... PL / TORRIX Ex XT...-A / TORRIX Ex XT... Flex / TORRIX Ex XT... PL / VISY-Stick Advanced ... / VISY-Stick ... Flex ... / VISY-Stick Advanced ... RS485 / VISY-Stick ... Flex ... RS485

	II 1 G	Ex ia IIB T6...T1 Ga
	II 1/2 G	Ex ia IIB T6...T1 Ga/Gb
	II 2 G	Ex ia IIB T6...T1 Gb
	II 2 D	Ex ia IIIC TX °C Db

TORRIX Exd ...

	II 1/2 G	Ex ia/db IIC T6...T1 Ga/Gb
	II 2 G	Ex db ia IIC T6...T1 Gb
	II 2 D	Ex ia tb IIIC TX °C Db

TORRIX Exd ...-A / TORRIX Exd ... Flex / TORRIX Exd ... PL

	II 1/2 G	Ex ia/db IIB T6...T1 Ga/Gb
	II 2 G	Ex db ia IIB T6...T1 Gb
	II 2 D	Ex ia tb IIIC TX °C Db

VISY-Stick ... TLS / VISY-Stick (Flex) Temp TLS

	II 1 G	Ex ia IIC T4...T1 Ga
	II 1/2 G	Ex ia IIC T4...T1 Ga/Gb
	II 2 G	Ex ia IIC T4...T1 Gb
	II 2 D	Ex ia IIIC TX °C Db

VISY-Stick Advanced ... TLS / VISY-Stick ... Flex ... TLS

	II 1 G	Ex ia IIB T4...T1 Ga
	II 1/2 G	Ex ia IIB T4...T1 Ga/Gb
	II 2 G	Ex ia IIB T4...T1 Gb
	II 2 D	Ex ia IIIC TX °C Db

- 5 Warning marking: *WARNING – Potential electrostatic charging hazard – See instructions
**WARNING – AFTER DE-ENERGIZING, DELAY 4 MINUTES BEFORE OPENING
- 6 CE marking: 0044
- 7 Ex d thread: **Cable entry, e.g. M20 × 1.5
- 8 Technical data: See instructions for technical data

* Marking only applies to sensors type VISY-Stick Sump ...

** Marking only applies to sensors type TORRIX Exd ...



V Technical data

The following electrical input values apply to the filling level sensors:

Electrical variable	TORRIX Ex SC... VISY-Stick ...	TORRIX Ex ... TORRIX Ex C... TORRIX Ex RS485... TORRIX Ex TAG... TORRIX Ex XT... VISY-Stick ... RS485	VISY-Stick ... TLS
$U_i \leq$	15 V	30 V	13 V
$I_i \leq$	60 mA	100 mA / 200 mA*	200 mA
$P_i \leq$	100 mW	1 W	625 mW
$C_i <$	10 nF	10 nF	20 nF
$L_i <$	100 μ H	20 μ H	410 μ H

Table 2: Electrical input data of intrinsic safe filling level sensors

The voltage for the type TORRIX Exd ... is from 12 V to 50 V ($U_m = 253$ V). The current is from 4 mA to 20 mA (Error mode: 3.6 mA / 21.5 mA) respectively 10 mA when using RS-485. The supply voltage of the heater is 24 V \pm 10 % with a current of 160 mA.

When using the equipment in potentially explosive atmospheres please consult table 3 to table 6 for the maximum temperatures depending on the equipment protection level and temperature class resp. surface temperature.

TORRIX Ex SC... / VISY-Stick ...

For use in EPL Ga, EPL Ga/Gb and EPL Gb		
Temperature class	T_a	T_F
T6	-40 °C ... +50 °C	-40 °C ... +75 °C
T5	-40 °C ... +65 °C	-40 °C ... +90 °C
T4	-40 °C ... +85 °C	-40 °C ... +125 °C
T3		-40 °C ... +190 °C
T2		-40 °C ... +285 °C
T1		-40 °C ... +435 °C
For use in EPL Db		
Maximum surface temperature		Ambient temperature T_a
dust layer \leq 5 mm	immersed in dust	
$X^\circ\text{C} = T_a + 30^\circ\text{C}$	$X^\circ\text{C} = 135^\circ\text{C}$	-40 °C ... +85 °C

Table 3: Service temperatures of the filling level sensors in basic version (without interface board)

The equipment is suitable for dusts whose ignition temperature under a dust layer of 5 mm is greater than 190 °C (glow temperature).

* The permissible input current I_i depends on the ambient temperature T_a



TORRIX Ex ... / TORRIX Ex C... / TORRIX Ex RS485... / TORRIX Ex TAG... / TORRIX Ex XT... / VISY-Stick ... RS485

For use in EPL Ga, EPL Ga/Gb and EPL Gb		
Temperature class	T _a	T _F
T6	$I_i \leq 100 \text{ mA: } -40 \text{ °C ... } +40 \text{ °C}$ $I_i \leq 200 \text{ mA: } -40 \text{ °C ... } +25 \text{ °C}$	-40 °C ... +75 °C
T5	$I_i \leq 100 \text{ mA: } -40 \text{ °C ... } +55 \text{ °C}$ $I_i \leq 200 \text{ mA: } -40 \text{ °C ... } +40 \text{ °C}$	-40 °C ... +90 °C
T4	$I_i \leq 100 \text{ mA: } -40 \text{ °C ... } +85 \text{ °C}$ $I_i \leq 200 \text{ mA: } -40 \text{ °C ... } +70 \text{ °C}$	-40 °C ... +125 °C
T3		-40 °C ... +190 °C
T2		-40 °C ... +285 °C
T1		-40 °C ... +435 °C
For use in EPL Db		
Maximum surface temperature		Ambient temperature T _a
dust layer ≤ 5 mm	immersed in dust	
$I_i \leq 100 \text{ mA: } X^{\circ}\text{C} = T_a + 40 \text{ °C}$	Consider EN 60079-14	-40 °C ... +85 °C
$I_i \leq 200 \text{ mA: } X^{\circ}\text{C} = T_a + 55 \text{ °C}$		-40 °C ... +70 °C

Table 4: Service temperatures of the filling level sensors with 4 ... 20 mA, RS-485 or TAG interface

The equipment is suitable for dusts whose ignition temperature under a dust layer of 5 mm is greater than 200 °C (glow temperature).

VISY-Stick ... TLS

For use in EPL Ga, EPL Ga/Gb and EPL Gb		
Temperature class	T _a	T _F
T4	-40 °C ... +75 °C	-40 °C ... +125 °C
T3	-40 °C ... +85 °C	-40 °C ... +190 °C
T2		-40 °C ... +285 °C
T1		-40 °C ... +435 °C
For use in EPL Db		
Maximum surface temperature		Ambient temperature T _a
dust layer ≤ 5 mm	immersed in dust	
X°C = 135 °C	X°C = 135 °C	-40 °C ... +77 °C
X°C = T _a + 110 °C	Consider EN 60079-14	-40 °C ... +85 °C

Table 5: Service temperatures of the filling level sensors with TLS interface

The equipment is suitable for dusts whose ignition temperature under a dust layer of 5 mm is greater than 270 °C (glow temperature).



TORRIX Exd ...

For use in EPL Ga/Gb and EPL Gb		
Temperature class	T _a	T _F
T6	-55 °C ... +50 °C	-55 °C ... +75 °C
T5	-55 °C ... +65 °C	-55 °C ... +90 °C
T4	-55 °C ... +85 °C	-55 °C ... +125 °C
T3		-55 °C ... +190 °C
T2		-55 °C ... +285 °C
T1		-55 °C ... +435 °C
For use in EPL Db		
Maximum surface temperature		Ambient temperature T _a
dust layer ≤ 5 mm	immersed in dust	
X°C = T _a + 30 °C	Consider EN 60079-14	-55 °C ... +85 °C

Table 6: Service temperatures of the Ex d+t+i version

The equipment is suitable for dusts whose ignition temperature under a dust layer of 5 mm is greater than 190 °C (glow temperature).

It must be ensured through appropriate measures that the temperature (T_a) for the respective temperature class is not exceeded at any point on the sensor head.

The filling level sensors achieve a degree of protection:

Protection rating IP68

VI Special conditions of use

1. When using plastic floats, the level sensors must be installed and used in such a way that electrostatic charges caused by operation, maintenance and cleaning are excluded.
For use in dust explosion hazardous areas, process-related electrostatic charges, e.g. due to media flowing past, must be excluded.
2. When using Titanium Floats or Sump Environmental Sensors, the risk of ignition due to impact or friction shall be avoided.
3. The flameproof joints at type TORRIX Exd ... are not intended to be repaired.

ZERTIFIKAT CERTIFICATE

Hiermit wird bescheinigt, dass das unten beschriebene Produkt der Firma
This certifies that the product mentioned below from company

FAFNIR GmbH
Schnackenburgallee 149 c
22525 Hamburg
Deutschland

die Anforderungen der folgenden Prüfunterlage(n) erfüllt.
fulfills the requirements of the following test regulations.

Geprüft nach: **EN 61508:2010, SIL 2**
Tested in accordance with:

Beschreibung des Produktes: **Magnetostriktiver Füllstandsensor**
(Details s. Anlage 1) *Magnetostrictive Level Sensor*
Description of product:
(Details see Annex 1)

Typenbezeichnung: **TORRIX ... (Version 4 & 5)**
Type Designation: **VISY-Stick ...**

Bemerkung: **Bitte beachten Sie auch die Hinweise in der Anlage**
Remark: **Please also pay attention to the Annex**

Dieses Zertifikat bescheinigt das Ergebnis der Prüfung an dem vorgestellten Prüfgegenstand. Eine allgemein gültige Aussage über die Qualität der Produkte aus der laufenden Fertigung kann hieraus nicht abgeleitet werden.
This certifies the result of the examination of the product sample submitted by the manufacturer. A general statement concerning the quality of the products from the series manufacture cannot be derived there from.

Registrier-Nr. / Registered No. 44 799 13752002
Prüfbericht Nr. / Test Report No. 3523 3926
Aktenzeichen / File reference 8000490968

Gültigkeit / Validity
von / from 2019-11-13
bis / until 2024-11-12



Zertifizierungsstelle der
TÜV NORD CERT GmbH

Essen, 2019-11-13

TÜV NORD CERT GmbH Langemarckstraße 20 45141 Essen www.tuev-nord-cert.de technology@tuev-nord.de

Bitte beachten Sie auch die umseitigen Hinweise
Please also pay attention to the information stated overleaf

Hinweise zum TÜV NORD- Zertifikat

Dieses TÜV NORD - Zertifikat gilt nur für die umseitig bezeichnete Firma und das angegebene Produkt. Es kann nur von der Zertifizierungsstelle auf Dritte übertragen werden.

Notwendige Bedienungs- und Montageanweisungen müssen jedem Produkt beigelegt werden.

Jedes Produkt muss deutlich einen Hinweis auf den Hersteller oder Importeur und eine Typenbezeichnung tragen, damit die Identität des geprüften Baumusters mit den serienmäßig in den Verkehr gebrachten Produkten festgestellt werden kann.

Der Inhaber des TÜV NORD - Zertifikates ist verpflichtet, die Fertigung der Produkte laufend auf Übereinstimmung mit den Prüfbestimmungen zu überwachen und insbesondere die in den Prüfbestimmungen festgelegten oder von der Zertifizierungsstelle geforderten Kontrollprüfungen ordnungsgemäß durchzuführen.

Bei Änderungen am geprüften Produkt ist die Zertifizierungsstelle umgehend zu verständigen.

Bei Änderungen und bei befristeten Zertifikaten ist das Zertifikat nach Ablauf der Gültigkeit urschriftlich an die Zertifizierungsstelle zurückzugeben. Die Zertifizierungsstelle entscheidet, ob das Zertifikat ergänzt werden kann oder ob eine erneute Zertifizierung erforderlich ist.

Für das TÜV NORD - Zertifikat gelten außer den vorgenannten Bedingungen auch alle übrigen Bestimmungen des allgemeinen Vertrages. Es hat solange Gültigkeit, wie die Regeln der Technik gelten, die der Prüfung zu Grunde gelegt worden sind, sofern es nicht auf Grund der Bedingungen des allgemeinen Vertrages früher zurückgezogen wird.

Dieses TÜV NORD - Zertifikat verliert seine Gültigkeit und muss unverzüglich der Zertifizierungsstelle zurückgegeben werden, falls es ungültig wird oder für ungültig erklärt wird.

Hints to the TÜV NORD - Certificate

This TÜV NORD - certificate only applies to the firm stated overleaf and the specified product. It may only be transferred to third parties by the certification body.

Each product must be accompanied by the instructions which are necessary for its operation and installation.

Each product must bear a distinct indication of the manufacturer or importer and a type designation so that the identity of the tested sample may be determined with the product launched on the market as a standard.

The bearer of the TÜV NORD - Certificate undertakes to regularly supervise the manufacturing of products for compliance with the test specifications and in particular properly carry out the checks which are stated in the specifications or required by the test laboratory.

In case of modifications of the tested product the certification body must be informed immediately.

In case of modifications and expiration of validity the original certificate must be returned to the certification body immediately. The certification body decides if the certificate can be supplemented or whether a new certification is required.

In addition to the conditions stated above, all other provisions of the General Agreement are applicable to the TÜV NORD - Certificate. It will be valid as long as the rules of technology on which the test was based are valid, unless revoked previously pursuant to the provisions of the General Agreement.

This TÜV NORD - Certificate will become invalid and shall be returned to the certification body immediately in the event that it shall expire without delay when it has expired or revoked.

ANLAGE ANNEX

Anlage 1, Seite 1 von 2
Annex 1, page 1 of 2

zum Zertifikat Registrier-Nr. / to Certificate Registration No. 44 799 13752002

Produktbeschreibung: <i>Product description:</i>	Siehe auch Seite 1 des Zertifikats <i>See also page 1 of the certificate</i>
Typbezeichnung: <i>Type designation:</i>	TORRIX ... (Version 4 & 5) VISY-Stick ...
Technische Daten: <i>Technical data:</i>	Versorgungsspannung: 8 V _{DC} ... 50 V _{DC} <i>Supply voltage:</i>
	Umgebungstemperatur: -40 °C ... +85 °C <i>Ambient temperature:</i>
	Schutzart: IP68 <i>Degree of Protection:</i>
Sicherheitsfunktion: <i>Safety function:</i>	Füllstandsmessung <i>Level Measurement</i>



Zertifizierungsstelle der
TÜV NORD CERT GmbH

Essen, 2019-11-13

ANLAGE ANNEX

Anlage 1, Seite 2 von 2
Annex 1, page 2 of 2

zum Zertifikat Registrier-Nr. / to Certificate Registration No. 44 799 13752002

Technische Daten:

Technical data:

- 1. Der Einsatz der Sensoren TORRIX ... (Version 4 & 5) und VISY-Stick ... hat unter Beachtung der durch den Hersteller vorgegebenen Sicherheitshinweise in der Technischen Dokumentation und im Sicherheitshandbuch der jeweils aktuellen Fassung zu erfolgen.**
The safety instructions of the manufacturer in the technical documentation / safety manual in its current valid version must be taken into consideration when using TORRIX ... (Version 4 & 5) and VISY-Stick... .
- 2. Für eine vollständige Beurteilung der funktionalen Sicherheit des Gesamtsystems müssen alle Anforderungen der EN 61508 auf alle Teilsysteme – und somit auf die gesamte Sicherheitsfunktion – angewendet werden.**
To accomplish a complete functional safety assessment of the whole system, all requirements of EN 61508 must be applied to all subsystems – and therefore to the overall safety function.
- 3. Die Gültigkeit der Bewertung ist ausschließlich für die im technischen Bericht 3523 3926, vom 08.11.2019 beschriebenen Hard- und Softwareversionen gegeben.**
The validity of the assessment is only given for the hard- and software versions described in technical report 3523 3926 as of 08.11.2019.



Zertifizierungsstelle der
TÜV NORD CERT GmbH

Essen, 2019-11-13

Safety manual in accordance with series of standards EN 61508

Level sensor type TORRIX ... and type VISY-Stick ...

Edition: 11.2019

I Range of application

The level sensors are suitable for areas in which a safety-related subsystem according to EN 61508 with SIL 2 is mandatory.

II Standards

The level sensors are designed in accordance with the following standards

EN 61508:2010, all parts Functional safety of electrical/electronic/programmable electronic safety-related systems

III Instructions for safe ...

III.a ... use

This safety manual applies to all level sensors from hardware version 4 and from firmware version 4.9 upwards. The version numbers can be read with differences:

TORRIX ... HART ...: The version numbers can be read out using the configuration program FAFNIR HART-Setup.

TORRIX ... RS485 ...: The firmware version can be read out using the MODBUS ASCII protocol.

TORRIX ... SC ... and VISY-Stick ...: The version numbers can be read out using the configuration program VISY-Setup or the FAFNIR protocol Universal Device Protocol (UDP). The respective technical documentation is to be consulted for the use of the named options.

TORRIX ... TAG ...: The firmware version is issued at regular intervals in the identification message. The field name is "Firmware Version" and has a length of two bytes.

In principle, the level sensor indicates the correct fill level (plausibility check) and / or, in the case of a detected error, an error value (safe state), which corresponds to a mode of operation with a continuous requirement. The safe state is reached within ten seconds. The safety function is ensured differently depending on the level sensor.

It must be ensured that there are no strong magnetic fields in the area of the probe tube. In addition, the safe use with adhering liquids is not guaranteed.

Type	Approval	Electrical design	Structure	Measuring accuracy	Mechanical design	Temperature range
						HHT Maximum temperature -40 °C ... +450 °C HT High temperature (HT) -40 °C ... +250 °C LLT Minimum temperature -200 °C ... +80 °C LT Low temperature -65 °C ... +125 °C NT Normal temperature -40 °C ... (+85) +125 °C
					<i>n</i> Rigid sensor tube with 12 mm diameter <i>n</i> = sensor tube Ø, e.g. 6 (mm) <i>nB</i> <i>n</i> = sensor tube Ø; Sensor tube not centered on the sensor head 90B Sensor tube bent 90° in front of the sensor head and Bypass B Sensor tube not centered on the sensor head (Bypass) Flex ... Flexible sensor tube (... Ø _{sensor tube} : F = 13 mm; T = 12 mm) PL Plastic coating against very aggressive media SP Sampling tube, e.g. for sampling	
					Standard -5T With five temperature sensors -A5T Increased measurement accuracy and five temperature sensors -A Increased measurement accuracy (Advanced)	
					Standard construction VT Internal structure vibration resistant for portable tanks	
					4 ... 20 mA interface with internal setting button C 4 ... 20 mA interface without internal setting button HART 4 ... 20 mA interface with HART protocol internal setting button HART C 4 ... 20 mA interface with HART protocol and without internal setting button RS485 RS-485 interface SC Serial communication (for connection to isolating amplifier VP-... or VPI) TAG TAG interface; signal transmission based on EN 14116	
					Without Ex approval Ex With Ex approval	

TORRIX Magnetostrictive level sensor (from version 5) with terminals or connection plug

Type code III.a1: Level sensor TORRIX ...

System	Type	Accuracy	Sensor tube	Usage	Interface
					For connection to isolating amplifier VP-... or VPI RS485 For connection to an RS-485 interface TLS For connection to a TLS (Veeder-Root)
				Standard level sensor Biodiesel Level sensor; Biodiesel E15 Level sensor; Ethanol admixture up to 15 % Ethanol Level sensor; Ethanol Interstitial Device for monitoring intermediate chambers in double-walled tanks LPG Level sensor; LPG N Level sensor; AdBlue Sump Environmental sensor for monitoring the dispenser sump with liquid distinction (product / water) Dispenser Sump Environmental sensor for monitoring the manhole with liquid distinction (product / water) Manhole Temp Temperature measuring chain with up to 32 temperature sensors	
				Rigid sensor tube Flex Flexible sensor tube	
				Standard Advanced Increased accuracy	
				Stick Magnetostrictive level and environmental sensor with up to five temperature sensors in the sensor tube	

VISY- Volume Information System

Type code III.a2: Level sensor VISY-Stick ...

III.b ... assembling and dismantling

For level sensors with connection board, only the cover of the connection housing may be removed for electrical installation and - by means of push buttons - for adjusting the level sensor. After installation, the connection housing must be closed again.

Also, the floats may be removed from the probe tube. When mounting the floats, pay attention to the correct orientation.

III.c ... installation

To integrate the devices in the equipotential bonding, a PA terminal is provided on the sensor head. For functional safety, it is relevant that the probes are integrated in the equipotential bonding. For the level sensors with screw terminals, the terminal designation is "+" and "-" For level sensors with M12 male connectors, the pin assignments are as follows:

Pin	TORRIX ... SC ... VISY-Stick ...	TORRIX ... C ... TORRIX ... TAG ... VISY-Stick ... TLS	TORRIX ... RS485 ... VISY-Stick ... RS485	M12 Cable (Female)
1	+	+	+	
2	A		A (+)	
3	-	-	-	
4	B		B (-)	

Table III.c: Terminal assignment of the sensors

III.d ... adjustment

No SIL-relevant adjustments are required for operation of the sensors.

III.e ... putting into service

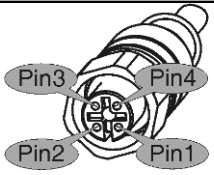
Before putting into service, all devices must be checked of right installation and connection. The electrical supply, as well of connected devices, must be checked.

III.f ... maintenance (servicing and emergency repair)

Generally, the level sensor is maintenance-free. In the event of a defect, it must be sent back to the manufacturer or one of its representations.

If an error occurs, e.g. no float on the probe tube, the corresponding diagnostic error is issued. If the error is corrected during active operation, the sensor leaves the error mode.

Level sensors with 4 ... 20 mA interface

In the event of a fault, the residual current flows (3.6 mA or 21.5 mA, whichever is set). If the fault current of 21.5 mA can not flow, e.g. if there is a low supply, the fault current of 3.6 mA is automatically set.

Level sensors with HART protocol

The second data byte of the level sensor response contains the device status. The flag "Device malfunction" (0x80, bit 7) signals a device error. If the "More Status Available" flag (0x10, bit 4) is also set, then device-specific status bits (byte 0) can be queried:

Bit	Fault	Description
0	HART parameters	HART parameters have been changed illegally
1	Sensor parameters	Sensor parameters have been changed illegally
2	Measurement	No measurement possible
3	Error counter	Too many errors during the measurement
4	Undervoltage	Supply voltage is too low

Table III.f1: Device-specific status bits in the HART protocol

Level sensors with DDA protocol:

In the event of an error, the error code "E102" is output in the fill level data field.

Level sensors with H, Modbus, UC and UDP protocol:

In the event of an error, the status code 1 is output.

Level sensors with LC protocol:

In the event of an error, the status bit (bit 7) in the status byte is set to 1.

Level sensors with TAG protocol

In the event of an error, the status bit (bit 23) is set to 1 and the fill level indicates the cause of the error:

Fill level (only bits 22 ... 0)	Status information
0x000000	General problem with the sensor
0x000001	RAM error
0x000002	Parameter error
0x000003	The float is too close to the end
0x000005	The float is upside down
0x000007	Switched ON (power up) or reset (Reset)
0x7FFFFFFF	Level overflow

Table III.f2: Device-specific status bits in the TAG protocol

Level sensors with TLS interface:

For each measurement, the probes are switched on for approximately 500 ms. If the probe is unable to perform regular measurements, the measurement is marked as invalid by falsification of the parity bit.

IV Safety related codes

Parameter	Value			
Safety Integrity Level	SIL 2			
Hardware fault tolerance	HFT = 0			
Security related subsystem	Type B			
Failure rate [h ⁻¹]	λ_{SD}	λ_{SU}	λ_{DD}	λ_{DU}
TORRIX ...	8.53E-09	3.46E-07	8.34E-07	1.38E-07
TORRIX ... C... / TORRIX ... TAG...	4.11E-08	3.13E-07	8.13E-07	1.20E-07
TORRIX ... HART C...	3.95E-08	3.59E-07	8.10E-07	1.16E-07
VISY-Stick ... RS485 / TORRIX ... RS485...	3.95E-08	2.65E-07	7.73E-07	1.10E-07
VISY-Stick ... / TORRIX ... SC...	3.95E-08	1.87E-07	7.25E-07	9.82E-08
VISY-Stick ... TLS	3.95E-08	2.33E-07	8.19E-07	1.15E-07
Mean frequency of dangerous failure per hour, PFH [h ⁻¹]	See failure rate λ_{DU}			
Mean Time to Recovery	MTTR = 8 h			
Interval of the retest	$T_1 = 1$ year			
Architecture	1001			

Table IV: Safety related codes

V Additional requirements for software elements

There are no requirements for software elements.



Government of India
Ministry of Commerce & Industry
Petroleum & Explosives Safety Organisation (PESO)
5th Floor, A-Block, CGO Complex, Seminary Hills,
Nagpur - 440006

E-mail : explosives@explosives.gov.in
 Phone/Fax No : 0712 -2510248, Fax-2510577

Approval No : A/P/HQ/MH/104/6555 (P479308)

Dated : 22/09/2020

To,

M/s. FAFNIR GmbH,
Scnackenburgallee 149 c,Hamburg
22525
GERMANY

Sub : Approval of Filling Level Sensors. under Petroleum Rules 2002- Regarding.

Sir(s),

Please refer to your letter No. **OIN576302** dated **11/09/2020** on the subject.

The following Ex electrical equipment(s) manufactured by you according to **EN 60079-11 : 2012, EN 60079-26 : 2015, EN/IEC 60079-0: 2018,** standards and covered under **TUV NORD CERT GmbH** Test reports mentioned below is/are approved for use in **Zone 0** of Gas **IIB/IIC** hazardous areas coming under the the Petroleum Rules, 2002 administered by this Organization.

Sr. No	Description	Safety Protection	Equipment reference Number	Test Agency			Drawing no
				Name	Certificate No.	Certificate Date	
1	Filling Level Sensor type VISY-Stick.. and type TORRIX Ex...	Ex ia IIC T6..T4 Ga or Ex ia IIB T6..T4 Ga or Ex ia IIC T6..T5 Ga or Ex ia IIB T6..T5 Ga or Ex ia IIC T4 Ga or Ex ia IIB T4 Ga	P479308/1	TUV NORD CERT GmbH	TUV 99 ATEX 1496 X Issue 02	19/02/2020	PF025B031 Rev B, PF025B059 Rev C

This Approval is granted subject to observance of the following conditions:-

- 1)The design and construction of the equipment shall be strictly in accordance with description, condition and drawings as mentioned in the TUV NORD CERT GmbH Test Reports referred to above.
- 2)The equipment shall be used only with approved type of accessories and associated apparatus.
- 3)Each equipment shall be marked either by raised lettering cast integrally or by plate attached permanently to the main structure to indicate conspicuously:-
 - (a) Name of the manufacturer
 - (b) Name and number by which the equipment is identified.
 - (c) Number & date of the test report of the TUV NORD CERT GmbH applicable to the equipment.
 - (d) Equipment reference number of this letter by which use of apparatus is approved.

(e) Protection level.

4) A certificate to the effect that the equipment has been manufactured strictly in accordance with the drawing referred to in the TUV NORD CERT GmbH Test report and is identical with the one tested and certified at TUV NORD CERT GmbH shall be furnished with each equipment.

5) The customer shall be supplied with a copy of this letter, an extract of the conditions and maintenance schedule, if any, recommended by TUV NORD CERT GmbH in their test reports and copy of instructions booklet detailing operation & maintenance of the equipment so as to maintain its Flame Proof characteristics.

6) The After sales service and maintenance of subject equipment shall be looked after by your representative Gilbarco Veeder Root India Pvt Ltd, B-Wing First Floor Art Guild House, Phoenix Market City, Kurla (West), Mumbai 400 070

This approval also covers the permissible variations as approved under the TUV NORD CERT GmbH test reports referred above. This approval is liable to be cancelled if any of the conditions of the approval is violated or not complied with . The approval may also be amended or withdrawn at any time, if considered necessary in the interest of safety.

The field performance report from actual users/your customers of the subject equipment may please be collected and furnished to this office for verification and record on annual basis.

The Approval is Valid upto **31/12/2024**

Yours faithfully,

(Ninad Dattaram Gawade)
Dy. Controller of Explosives
For Chief Controller of Explosives
Nagpur

Copy to :

1. Jt. Chief Controller of Explosives, West Circle, MUMBAI
2. Gilbarco Veeder Root India Pvt Ltd, B-Wing First Floor Art Guild House, Phoenix Market City, Kurla (West), Mumbai 400 070

for Chief Controller of Explosives
Nagpur

(For more information regarding status, fees and other details please visit our website <http://peso.gov.in>)

This is System Generated document. Signature is not required.

Disclaimer : This page gives the latest action taken by this organization on your application. This page is made available for the information of concerned applicant/licensee only. All efforts have been made to secure this information. However, PESO will not be responsible for any misuse of the information by unauthorized persons including the hackers.



Blank Page

Blank Page



FAFNIR GmbH
Schnackenburgallee 149 c
22525 Hamburg, Germany
T: +49 / 40 / 39 82 07- 0
E-mail: info@fafnir.com
Web: www.fafnir.com
